

SMART TOOLS FOR EVERY JOB

15 YEARS
ANNIVERSARY

MANDREX

Smart tools for every job



PRODUCT CATALOGUE

ENGLISH



WWW.MANDREX-SYSTEM.COM



MANDREX Smart tools for every job

Founded in the Netherlands in 2009, as MandreX Hole Saw System, we always supply the best quality products to our customers all over the world. We are dedicated to continually testing and improving our products to ensure quality results and maximum lifetime.

Maintaining our standard as one of the world's leading manufacturers is important to us, and precisely what you should expect from a company like MandreX Hole Saw System.

We are committed to ensure our high quality standards and are constantly working on improvements and innovations. Continuous product development and long testing phases mean our products meet the highest quality standards.











Our customer service, quality control and maintaining the highest standards are fundamental to our company. We are proud of our reputation for innovation, quality and customer service.

After becoming a major and trustworthy player in the world-wide hole saw market we continued working on the wishes from our customers to design innovative problem solvers for other tools as well. Bringing standard tools on the market is not our challenge, being innovative and solving problems is our challenge for the past and many years to come. Each Mandrex tool is a problem solver, even for the most difficult jobs.









Using the Smart tools from Mandrex saves you time, money and frustration!







PRODUCT TYPE

-  Carbide Tipped Hole Saw
-  Extra Long Multi-purpose Hole Saw
-  M42 Bi-metal Hole Saw
-  Extra Long M42 Bi-metal Hole Saw
-  M42 Fine Bi-metal Hole Saw
-  Bi-metal Hole Saw
-  Diamond Grid Hole Saw
-  Diamond Segmented core drill
-  Pilot drill - Carbide Tipped
-  Pilot drill - HSS High Speed Steel
-  Pilot drill - Diamant grid





TEETH CONFIGURATION

-  Bi-Metal teeth
-  Bi-Metal teeth with 8% Cobalt (M42)
-  Tri-Metal teeth
-  Tungsten Carbide Teeth (TCT - Widia)
-  Tungsten Carbide Grit
-  Chrome Vanadium Teeth
-  Diamond Grit / Diamond Coated
-  Diamond Segmented
-  Laser welded































MACHINE TYPE

-  Suitable for battery power tools
-  Suitable for electric power tools
-  Suitable for electric grinders
-  Suitable for jig saws
-  Suitable for reciprocating saws











CONNECTION

-  Hexagon shank 8,5mm - 11/32"
-  Hexagon shank 11mm - 7/16"
-  Powerbit connection
-  SDS plus shank





MATERIALS

- | | |
|---|---|
|  Wood |  Common plastics / PVC |
|  Soft wood |  Acrylic |
|  MDF |  Reinforced plastics |
|  Wood with nails |  Fibre cement board |
|  Multiplex / Plywood |  Soft stone Gypsum / Stucco |
|  Laminated board |  Brickwork |
|  Laminate |  Solid hard brick / Pavement |
|  Pallets |  Normal concrete |
|  Window frames |  Wall tiles |
|  Garden wood |  Hard (floor-) tiles |
|  Steel/Iron |  Natural stone / marble |
|  Sheet steel |  Aerated concrete |
|  Stainless Steel / Inox |  Framing |
|  Steel profiles / tubes |  Plasterboard |
|  Non ferrous | |
|  Cast iron | |

ADDITIONAL

-  All the benefits of the MXqs system
-  The ONE CLICK MXqs system
-  Fast performance
-  5 times faster compared to others
-  High speed performance
-  Longer lifetime
-  10 times longer life time
-  Pieces per packaging
-  Centering device
-  Recommended speed (RPM)

COOLING

-  Cooling wax/spray
-  Cool down with water
-  Use without water
-  Cool down with less water

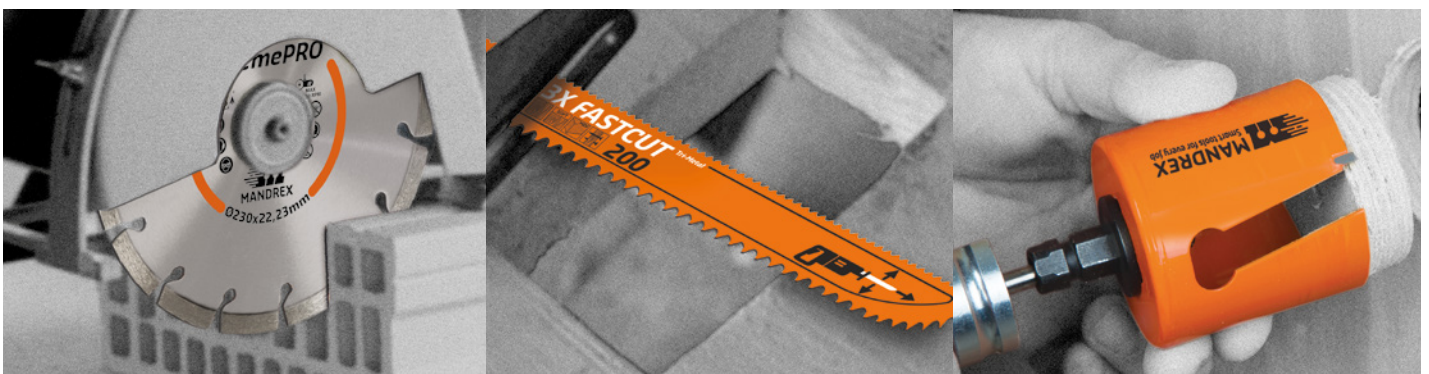

CATALOGUE CONTENT

“ONE CLICK” HOLE SAW SYSTEM

THE MXQs “ONE CLICK” HOLE SAW SYSTEM	4
MXQs ARBORS	6
MXQs PILOT DRILLS	7
MXQs ADAPTERS	7
MXQs HOLE ENLARGEMENT	7

HOLE SAWS

HOLE SAW SELECTOR	8
HOLE SAW SPEED CHART	9
ALL-PURPOSE ULTRAXCUT	10
MULTI-PURPOSE SUPERXCUT	11
BI-METAL SPEEDXCUT M42	12
BI-METAL FINEXCUT M42	13
BI-METAL EASYXCUT M3	14
MULTI-PURPOSE SUPERXCUT XTRA DEEP 165MM	15
MULTI-PURPOSE SUPERXCUT XTRA DEEP 165MM MXQs	16
MULTI-PURPOSE SUPERXCUT XTRA DEEP 300MM MXQs	17
BI-METAL SPEEDXCUT XTRA DEEP 165MM MXQs	18
BI-METAL SPEEDXCUT XTRA DEEP 300MM MXQs	19

HOLE SAW KITS

HOLE SAW KITS FOR EVERY JOB	20
STARTER KITS	21
ALL-PURPOSE ULTRAXCUT KITS	22
MULTI-PURPOSE SUPERXCUT KITS	23
BI-METAL SPEEDXCUT M42 KITS	24
SUPERXCUT + SPEEDXCUT M42 KIT	24
BI-METAL FINEXCUT M42 KITS	25
BI-METAL EASYXCUT M3 KITS	25

CONVENTIONAL ARBORS

ARBORS	26
PILOT DRILLS	26
ADAPTERS & EXTENSIONS	26

DIAMOND HOLE SAWS

DIAMOND ProXCUT	28
ProXCUT PILOT DRILL	29
DIAMOND DryXCUT	30
DIAMOND DryXCUT KITS	31
DryXCUT PILOT DRILL	31
DIAMOND TileXCUT	32
DIAMOND UniXCUT	33
DIAMOND CORE DRILLS CONCRETEXDry	34
DIAMOND CORE DRILLS CONCRETEXDUST DUSTFREE	35

ACCESSORIES FOR HOLE SAWS

COOLING WAX	36
CENTERING & COOLING AID	36
COOLING GEL	36
WATER SPRAY BOTTLE	36
MANUAL CENTERING TOOL	37
VACUUM CENTERING TOOL	37
DUST & SLURRY TOOL - SMALL	37
DUST & SLURRY TOOL - BIG	37

WOOD DRILLS

ULTIMATE SPEEDXBIT	38
ULTIMATE TWISTERXBIT	39
ULTIMATE 4X POWERXBIT	40

RECIPROCATING SAW BLADES

RECIPROCATING SAW BLADE SELECTOR	41
3X FASTCUT	42
STEELCUT	42
MULTICUT	43
MULTICUT VARIA	43
MULTICUT DEMOLITION & RENOVATION	43
HARDCUT	44
TOUGHCUT	44
WOODCUT	44

JIG SAW BLADES

JIG SAW BLADE SELECTOR	45
COOLCUT	46
DUOCUT	46
DUOCUT VARIA	46
SHARPCUT VARIA	47
MULTI-PURPOSE-PACK (5PCS)	47

DIAMOND SAW BLADES

DIAMOND SAW BLADE SELECTOR	48
CONCRETE - XTREMEPRO	49
UNIVERSAL - XTREMEPRO	50
UNIVERSAL - PROFI	50
UNIVERSAL - STANDARD	50
TILES - XTREMEPRO	51
TILES - PROFI	51
BRICKS - XTREMEPRO	51

DIAMOND CUT-OFF DISCS

DIAMOND CUT-OFF DISC METALXCUT	52
--------------------------------------	----

PIPE CUTTER

EZYGRIND - DIAMOND COATED PIPE CUTTER	53
---	----

THE MXqs "ONE CLICK" HOLE SAW SYSTEM

Experience the future in arbor systems: better, faster and more efficient than all other existing arbors in the market.

MXqs

ONE
CLICK



Replace your Hole Saw with ONE CLICK

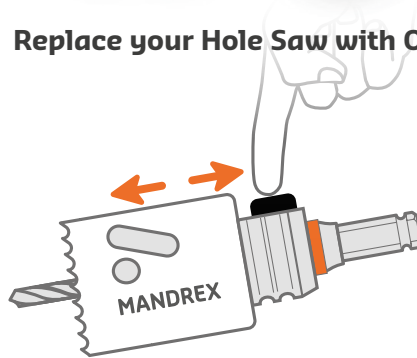

To remove the Hole Saw to use another diameter, just push the button and exchange the Hole Saw. Slide on another Hole Saw and you are ready to go.

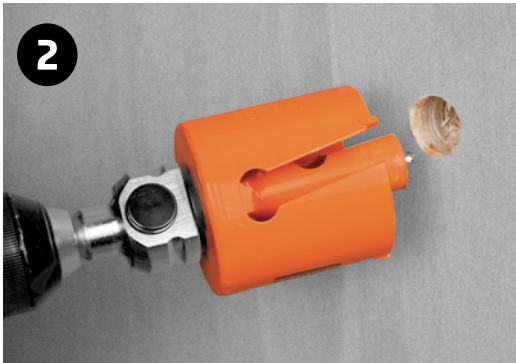

Enlarge previously drilled holes



Simple! You can now use the smaller Hole Saw to center the drill. It is easy to drill a hole with the desired diameter. Extra adapter needed.



Eject the plug with ONE CLICK

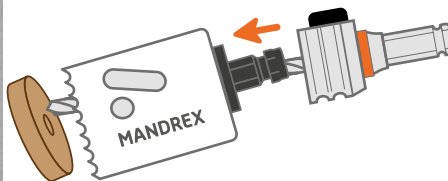

Just push the button, move the Hole Saw back and forth and you have released the core! Drill the next hole easily and quickly, without struggling or waiting.



1 Arbor for large and small Hole Saws

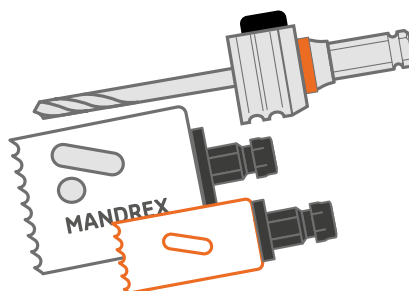

Only one arbor needed for all Hole Saw diameters. No further need to have 2 arbors for large and small diameters.

replace and mount every Hole Saw with ONE CLICK



ONE CLICK

For all drilling machines

SDS+ 8,5 11 P

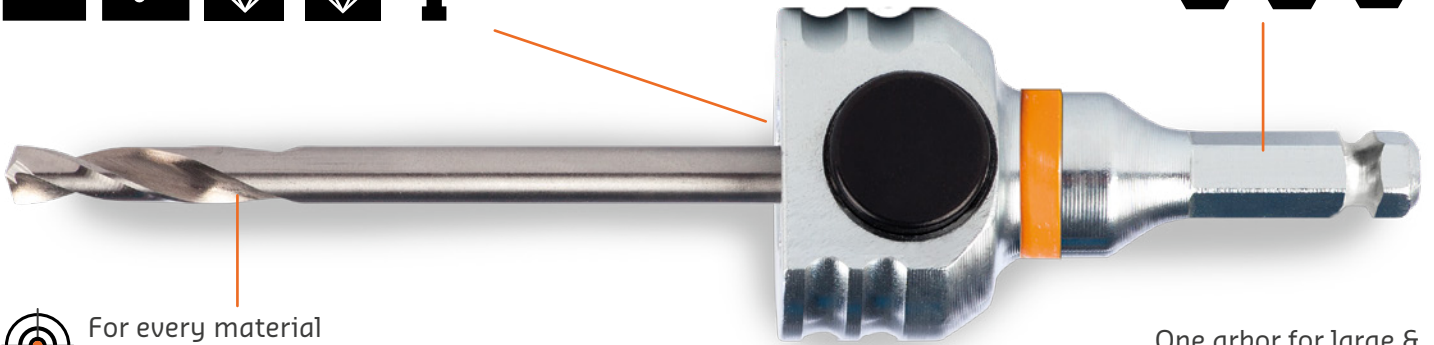

For every material there is a suitable pilot drill

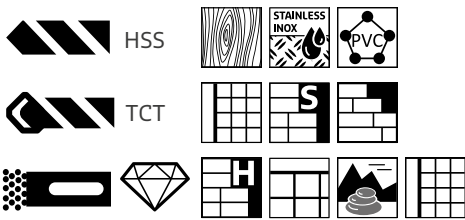

One arbor for large & small diameter Hole Saws

Ø14-210mm



Exchanging Hole Saws is a matter of pushing the button and slide. With the MXqs arbors you only require one arbor for large and small Hole Saws. With our unique ONE CLICK arbor system it only takes seconds. Making use of the unique Mandrex MXqs arbor system brings you all its unique features with one simple CLICK.

Just push the button and start saving time, money and frustration!



The patented Mandrex MXqs "ONE Click" system is licensed to Mandrex Hole Saw System in the Netherlands for distribution worldwide

MXqs ARBORS

The MXqs arbors can be used on all drilling machines, in combination with all Hole Saws. Just choose the correct combination of arbor and pilot drill and start drilling!



60mm	45mm	38mm	Hex 11 7/16"	Hex 8,5 11/32"	SDS Plus	HSS Steel	Tungsten Carbide Tip	e.g. Wood Steel Plastic	Brickwork (soft)stone Wall tiles

Arbor Part No.	Can be used with this Hole Saw			Machine chuck size		Pilot drill		Material to drill	
	TCT	Bi-metal	Bi-metal	Hex 11 7/16"	Hex 8,5 11/32"	Hex 11 7/16"	Hex 8,5 11/32"	Wood	Steel
MX200020B	●	●		●		●		●	
MX200021B	●			●			●		●
MX200022B			●	●		●		●	
MX200024B	●	●			●	●		●	
MX200025B	●				●		●		●
MX200026B		●			●	●		●	
MX200020SB	●	●				●		●	
MX200021SB	●						●		●
MX200022SB			●			●		●	

	MX200020B	MXqs Arbor Complete For TCT & Bi-metal Hole Saws With HSS Pilot drill	Drill Chuck Hex 11 - 7/16"PB. E.g. for wood, plastics, steel, stainless	With pilot drill MX2P0063B L=125mm
	MX200021B	MXqs Arbor Complete For TCT Hole Saws. With Carbide tipped pilot drill	Drill Chuck Hex 11 - 7/16"PB. E.g. for concrete, sandstone, brickwork, soft tiles	With pilot drill MX2P0062B L=125mm
	MX200022B	MXqs Arbor Complete For SHORT Bi-metal Hole Saws. With short HSS Pilot drill	Drill Chuck Hex 11 - 7/16"PB. E.g. for wood, plastics, steel, stainless	With pilot drill MX2P0064B L=105mm
	MX200024B	MXqs Arbor Complete For TCT & Bi-metal Hole Saws With HSS Pilot drill	Drill Chuck Hex 8,5 - 11/32"PB. E.g. for wood, plastics, steel, stainless	With pilot drill MX2P0063B L=125mm
	MX200025B	MXqs Arbor Complete For TCT Hole Saws. With Carbide tipped pilot drill	Drill Chuck Hex 8,5 - 11/32"PB. E.g. for concrete, sandstone brickwork, soft tiles	With pilot drill MX2P0062B L=125mm
	MX200026B	MXqs Arbor Complete For SHORT Bi-metal Hole Saws. With short HSS Pilot drill	Drill Chuck Hex 8,5 - 11/32"PB. E.g. for wood, plastics, steel, stainless	With pilot drill MX2P0064B L=105mm
	MX200020SB	MXqs Arbor SDS-PLUS Complete For TCT & Bi-metal Hole Saws With HSS Pilot drill	Drill Chuck SDS-plus. E.g. for wood, plastics, steel, stainless	With pilot drill MX2P0063B L=125mm
	MX200021SB	MXqs Arbor SDS-plus Complete For TCT Hole Saws. With Carbide tipped pilot drill	Drill Chuck SDS-plus. E.g. for concrete, sandstone brickwork, soft tiles	With pilot drill MX2P0062B L=125mm
	MX200022SB	MXqs Arbor SDS-PLUS Complete For SHORT Bi-metal Hole Saws. With short HSS Pilot drill	Drill Chuck SDS-plus. E.g. for wood, plastics, steel, stainless	With pilot drill MX2P0064B L=105mm

MXqs PILOT DRILLS



HSS Steel



Tungsten Carbide Tip



60mm Carbide tipped TCT



45mm Bi-metal



38mm Bi-metal

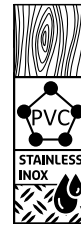

e.g. Wood Steel Plastic



Brickwork (soft)stone Wall tiles



Steel Stainless 1000N/mm²

Pilot drill Part No.	Pilot drill type		Can be used with this Hole Saw			Material to drill		
MX2P0062B		●	●				●	
MX2P0063B	●		●	●		●		
MX2P0064B	●				●			
MX2P0068B	●			●				●

MX2P0062B



Pilot drill with Tungsten carbide percussion drill tip (TCT) - L=125mm Ø7mm

E.g. for concrete, (sand-)stone, brickwork, tiles

MX2P0063B



Pilot drill HSS M2 with 135 degrees split point for smooth drilling - L=125mm Ø6,35mm

E.g. for wood, plastics, (stainless) steel

MX2P0064B



Pilot drill HSS - Short - L=105mm Ø6,35mm

E.g. for wood, plastics, (stainless) steel

MX2P0068B



Pilot drill HSS-Co with 8% Cobalt and 135 degrees split point for smooth drilling L=125mm Ø6,35mm

E.g. for Stainless/Inox, (cast-) iron, steel with tensile strength till 1000N/mm²

MXqs ADAPTERS



Diameter Hole Saw

Adapter Part No.	Qty. Pieces per pack	Ø14-30	Ø32-150	Ø152-210	Nm High Torque
MX2P0053B	3	●			
MX2P0052B	3		●		
MX2P0052HB	3			●	●



MX2P0053B

MXqs ONE CLICK adapter for all types of Hole Saws

1/2"-20UNF thread for Hole Saw diameters Ø14-30mm



MX2P0052B

MXqs ONE CLICK adapter for all types of Hole Saws

5/8"-18UNF thread for Hole Saw diameters Ø32-150mm



MX2P0052HB

MXqs High Torque ONE CLICK adapter for all types of Hole Saws, including screws

For Hole Saw diameters Ø152-210mm



MX2P0052FB

MXqs ONE-CLICK adapter special

For hole saws with M24 thread. 3 pieces/pack

MXqs HOLE ENLARGEMENT



MX2P0052HEB

Set with 3 adapters to enlarge the previously drilled hole.

- 1 adapter for using Hole Saws with 1/2" thread
- 1 adapter for using Hole Saws 1/2" and 5/8" thread
- 1 adapter for using Hole Saws with 5/8" thread



HOLE SAW SELECTOR

The table shows the performance compared to each other!
Diverse requirements are taken into consideration e.g. speed, lifetime, roughness of the hole.

- Best choice
- Good
- Possible

CARBIDE TIPPED



	UltraXcut TCT	SuperXcut TCT	SpeedXcut M42	FineXcut M42	EasyXcut M3	ProXcut Diamond	DryXcut Diamond	UniXcut TileXcut	Xdry Xdust

CUTTING DEPTH (MM)	60	60	45	38	45	38	35	28	60
LIFETIME	●	●	●	●		●	●		
CUTTING SPEED	●	●	●			●	●		
CLEAN HOLES	●		●	●				●	

	UltraXcut TCT	SuperXcut TCT	SpeedXcut M42	FineXcut M42	EasyXcut M3	ProXcut Diamond	DryXcut Diamond	UniXcut TileXcut	Xdry Xdust
WOOD									
SOFT WOOD	●	●	●		●				
HARD WOOD	●	●	●		●				
WOOD WITH NAILS	●	●	●		●				
CHIPBOARD	●	●	●		●				
PLYWOOD	●	●	●		●				
MDF	●	●	●		●				
SANDWICH	●	●							
PALLET	●		●		●				
WINDOW FRAME	●		●	●	●				
LAMINATE	●	●	●		●				
STEEL									
MILD STEEL	●	●	●	●	●				
CARBON STEEL	●	●	●		●				
STAINLESS STEEL	●	●	●	●					
THIN SHEET METAL	●		●	●					
CAST IRON			●						
METAL PIPE	●		●		●				
COPPER / BRASS	●		●		●				
ALUMINIUM	●		●		●				
MASONRY	●	●				●	●	●	●
ABBRASSIVE									
PLASTERBOARD	●	●							
FIBER CEMENT BOARD	●	●							
SOFT STONE	●	●				●	●	●	●
GYPHUM	●	●							
SOFT TILES	●	●				●	●	●	●
SOFT CONCRETE	●	●							●
BRICK	●	●				●	●	●	●
AERATED CONCRETE	●	●							
PLASTIC									
PVC PLASTIC	●	●	●		●				
ACRYLIC	●	●	●		●				
FIBREGLASS	●	●	●		●				
CARBON FIBRE	●	●							
REINFORCED PLASTIC	●	●	●						
HARD									
CONCRETE									●
MARBLE						●	●	●	
NATURE STONE						●	●	●	
HARD FLOOR TILES						●	●	●	●
HARD BRICK						●			●

HOLE SAW SPEED CHART

The speeds shown, which are a guideline to optimize performance, may vary because of the torque and wattage of the power tool used, density and hardness of the material. Never go faster than the suggested speed as indicated in the table.



All-purpose
UltraXcut (TCT)
CARBIDE-TIPPED



Ø MM	Ø INCH	(Hard-)wood		Carbon Steel		Stainless		Non Ferro		Aluminium		Plastics like PVC		Fiber Glass		Soft Tiles Gypsum Soft bricks	
		MDF	wood with nails														
19-27	3/4" - 1 1/16"	3690	2595	605	425	470	335	985	695	1845	1300	3355	2360	590	415	505	355
29-51	1 1/8" - 2"	2420	1375	400	225	310	175	645	370	1210	690	2200	1250	385	220	330	190
54-76	2 1/8" - 3"	1300	1005	215	165	170	130	350	270	650	505	1180	910	210	150	180	140
89-114	3 1/2" - 4 1/2"	925	615	155	105	120	80	250	165	465	310	840	560	150	100	130	85
121-168	4 3/4" - 6 5/8"	580	420	95	70	75	55	155	115	290	210	530	380	95	70	80	60



Multi-purpose
SuperXcut (TCT)



Ø MM	Ø INCH	(Hard-) Wood MDF		Plastic like PVC		Brickwork Gypsum		Soft/wall tiles	
16-38	5/8" - 1 1/2"	4380	1845	2990	1260	1795	755	1295	545
40-51	1 9/16" - 2"	1755	1375	1195	940	720	565	520	410
54-76	2 1/8" - 3"	1350	890	920	605	555	365	400	265
80-108	3 5/32" - 4 1/4"	880	650	600	445	360	270	260	195
111-210	4 3/8" - 8 1/4"	635	335	435	230	260	140	190	100



Bi-Metal
SpeedXcut M42
FineXcut M42
EasyXcut M3



Ø MM	Ø INCH	(Hard-)wood		MDF		Carbon Steel		Stainless		Non Ferro		Aluminium		Cast Iron		Plastics like PVC	
14-27	9/16" - 1 1/16"	2845	1475	2275	1180	595	310	300	155	890	465	910	475	455	240	910	475
29-51	1 1/8" - 2"	1375	785	1100	625	290	165	145	85	430	245	440	250	220	125	440	250
52-76	2 1/16" - 3"	770	525	615	420	160	110	80	55	240	165	245	170	125	85	245	170
79-102	3 1/8" - 4"	505	395	405	315	105	85	55	45	160	125	165	125	85	65	165	125
105-152	4 1/8" - 6"	380	265	305	210	80	55	40	30	120	85	125	85	65	45	125	85
160-210	6 5/16" - 8 1/4"	250	190	200	155	55	40	30	20	80	60	80	65	40	35	80	65



Diamond
ProXcut



Ø MM	Ø INCH	Hard Brick Wall & Floor tiles	
		Natural stone	
19-29	3/4" - 1 1/8"	1180	770
32-51	1 1/4" - 2"	700	440
54-65	2 1/8" - 2 9/16"	420	350
68-83	2 11/16" - 3 1/4"	330	270
92-114	3 5/8" - 4 1/2"	250	200



Diamond
DryXcut



Ø MM	Ø INCH	Hard Brick Wall & Floor tiles	
		Natural stone	
5-132	3/16" - 5 3/16"	6500-3000	



Diamond
UniXcut
TileXcut



Ø MM	Ø INCH	Hard Brick Wall & Floor tiles	
		Natural stone	
5-35	3/16" - 1 3/8"	3000-1500	

ALL-PURPOSE ULTRAXCUT CARBIDE TIPPED

The Hole Saw with **Carbide Teeth (TCT)** which cut into the **widest range of materials**. With a unique auto-precision grinded carbide tooth style for clean and high performance cutting. Up to 50 times the lifetime, 2 times faster and 3 times more holes per battery charge.

The beam welded Carbide tipped teeth are made of a specially developed fine grain, highest grade carbide, resulting in outstanding cutting performance and product durability. With a cutting depth of 60mm (2 3/8") you can make deeper holes in a single pass.

Fast cutting in **all common materials** like e.g. **(stainless-) steel, wood (with nails), plastic, soft tiles, gypsum, soft bricks**. Easy core ejection because of the optimized release slots.

FEATURES

- Widest range of materials
- Up to 2 times faster & 50 times the lifetime (compared to Bi-Metal)
- Optimized heat resistant carbide teeth, lesser cooling needed
- Cutting depth 60mm (2-3/8") for deeper holes in one pass
- Large clearance of chips: specially designed slots
- Easy release of the core
- Hardened steel wall
- Very clean cuts, also at the entry and exit
- Suitable for use in electric, battery powered tools & bench drills

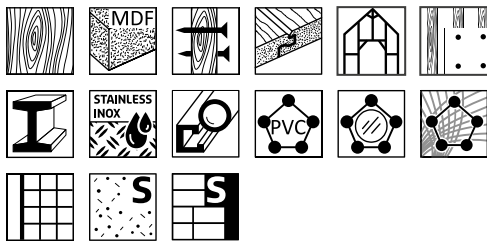

50x LIFE TIME **2x FASTER**

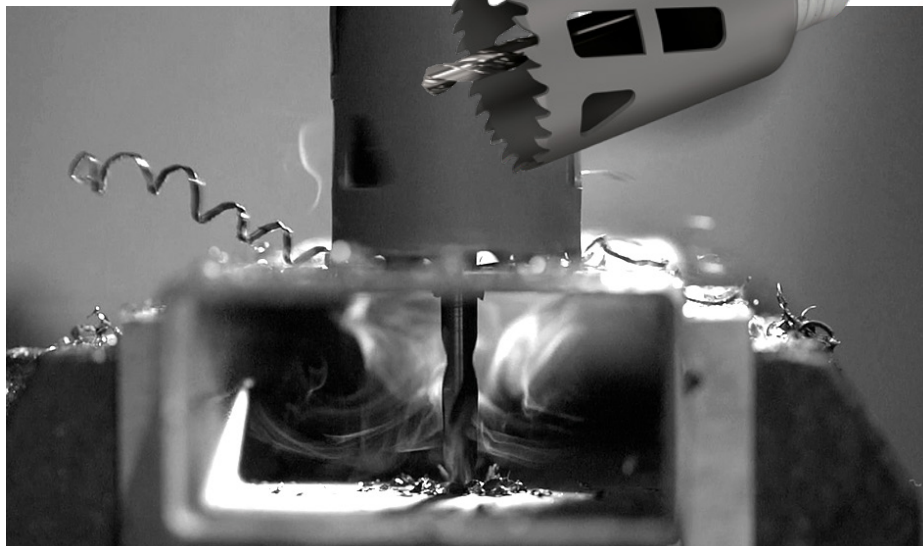

Part No.	Ø MM	Ø INCH
MHTQ0019B	19	3/4
MHTQ0020B	20	25/32
MHTQ0022B	22	7/8
MHTQ0025B	25	1
MHTQ0027B	27	1 1/16
MHTQ0029B	29	1 1/8
MHTQ0030B	30	1 3/16
MHTQ0032B	32	1 1/4
MHTQ0035B	35	1 3/8
MHTQ0038B	38	1 1/2
MHTQ0041B	41	1 5/8
MHTQ0044B	44	1 3/4
MHTQ0048B	48	1 7/8
MHTQ0051B	51	2
MHTQ0054B	54	2 1/8
MHTQ0057B	57	2 1/4
MHTQ0060B	60	2 3/8
MHTQ0064B	64	2 1/2
MHTQ0065B	65	2 9/16
MHTQ0067B	67	2 5/8
MHTQ0068B	68	2 11/16
MHTQ0070B	70	2 3/4
MHTQ0073B	73	2 7/8
MHTQ0076B	76	3
MHTQ0079B	79	3 1/8
MHTQ0083B	83	3 1/4
MHTQ0089B	89	3 1/2
MHTQ0092B	92	3 5/8
MHTQ0095B	95	3 3/4
MHTQ0102B	102	4
MHTQ0105B	105	4 1/8
MHTQ0108B	108	4 1/4
MHTQ0111B	111	4 3/8
MHTQ0114B	114	4 1/2
MHTQ0121B	121	4 3/4
MHTQ0127B	127	5
MHTQ0133B	133	5 1/4
MHTQ0140B	140	5 1/2
MHTQ0152B	152	6
MHTQ0160B	160	6 5/16
MHTQ0168B	168	6 5/8

MULTI-PURPOSE SUPERXCUT

The fastest Hole Saw with unique carbide tooth set for clean and high performance cutting. Easily 10 times the lifetime compared to Bi-metal Hole Saws. Carbide tipped teeth are made of a specially developed construction grade carbide, resulting in outstanding cutting performance and product durability.

FEATURES

- 5 times faster and 10 times the lifetime compared to any competitive Hole Saw
- Cutting depth 60mm (2-3/8") for deeper holes in one pass
- Large clearance of chips thanks to the specially designed wide slots
- Smooth cutting with minimal heat build-up
- Suitable for use in electric and battery powered tools

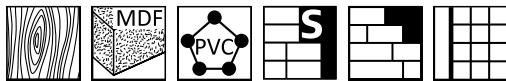

MXqs

ONE CLICK



Part No.*	Ø MM	Ø INCH	Part No.*	Ø MM	Ø INCH
MHMQ0016B	16	5/8	MHMQ0065B	65	2 9/16
MHMQ0017B	17	11/16	MHMQ0067B	67	2 5/8
MHMQ0019B	19	3/4	MHMQ0068B	68	2 11/16
MHMQ0020B	20	25/32	MHMQ0070B	70	2 3/4
MHMQ0021B	21	13/16	MHMQ0073B	73	2 7/8
MHMQ0022B	22	7/8	MHMQ0074B	74	2 15/16
MHMQ0024B	24	15/16	MHMQ0076B	76	3
MHMQ0025B	25	1	MHMQ0079B	79	3 1/8
MHMQ0027B	27	1 1/16	MHMQ0080B	80	3 5/32
MHMQ0029B	29	1 1/8	MHMQ0082B	82	3 15/64
MHMQ0030B	30	1 3/16	MHMQ0083B	83	3 1/4
MHMQ0032B	32	1 1/4	MHMQ0086B	86	3 3/8
MHMQ0033B	33	1 5/16	MHMQ0089B	89	3 1/2
MHMQ0035B	35	1 3/8	MHMQ0092B	92	3 5/8
MHMQ0037B	37	1 7/16	MHMQ0095B	95	3 3/4
MHMQ0038B	38	1 1/2	MHMQ0098B	98	3 7/8
MHMQ0040B	40	1 9/16	MHMQ0102B	102	4
MHMQ0041B	41	1 5/8	MHMQ0105B	105	4 1/8
MHMQ0043B	43	1 11/16	MHMQ0106B	106,5	4 3/16
MHMQ0044B	44	1 3/4	MHMQ0108B	108	4 1/4
MHMQ0046B	46	1 13/16	MHMQ0111B	111	4 3/8
MHMQ0048B	48	1 7/8	MHMQ0114B	114	4 1/2
MHMQ0050B	50	1 31/32	MHMQ0121B	121	4 3/4
MHMQ0051B	51	2	MHMQ0127B	127	5
MHMQ0052B	52	2 1/16	MHMQ0133B	133	5 1/4
MHMQ0054B	54	2 1/8	MHMQ0140B	140	5 1/2
MHMQ0056B	56	2 3/16	MHMQ0146B	146	5 3/4
MHMQ0057B	57	2 1/4	MHMQ0152B	152	6
MHMQ0059B	59	2 5/16	MHMQ0160B	160	6 5/16
MHMQ0060B	60	2 3/8	MHMQ0168B	168	6 5/8
MHMQ0064B	64	2 1/2	MHMQ0177B	177	6 31/32
			MHMQ0200B	200	7 7/32
			MHMQ0210B	210	8 1/4



MULTI-PURPOSE SUPERXCUT COUNTERSINK

MHMQ0068LB SuperXcut hole saw Ø68 with countersink ring Ø73 and MXqs adapter

MX200091B Tungsten carbide countersink ring Ø73

*To order this type of Hole Saw without MXqs adapter, replace "Q" in the Part No. with "O"

BI-METAL SPEEDXCUT M42

Long lasting Bi-metal Hole Saws with unique ejection holes for extra chip release and weight reduction. Hardened steel, in combination with our special tooth geometry, provides the smoothest cut requiring less feed pressure.

FEATURES

- Extra release holes to push out thin plate core material easily
- Bi-metal with 8% cobalt alloy for a longer lifetime
- Cutting depth 45mm (1-3/4") for deeper holes in one pass
- Maximum clearance of chips thanks to the specially designed wide slots
- 4/6" variable teeth for clean edges
- Significant weight reduction compared to any other Hole Saws
- Smooth cutting with minimal heat build up
- Suitable for use in electric and battery powered tools

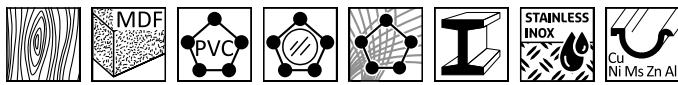

MXqs

ONE CLICK



*To order this type of Hole Saw without MXqs adapter, replace "Q" in the Part No. with "0"

Part No.*	Ø MM	Ø INCH	Part No.*	Ø MM	Ø INCH
MHB4Q014B	14	9/16	MHB4Q065B	65	2 9/16
MHB4Q016B	16	5/8	MHB4Q067B	67	2 5/8
MHB4Q017B	17	11/16	MHB4Q068B	68	2 11/16
MHB4Q019B	19	3/4	MHB4Q070B	70	2 3/4
MHB4Q020B	20	25/32	MHB4Q073B	73	2 7/8
MHB4Q021B	21	13/16	MHB4Q076B	76	3
MHB4Q022B	22	7/8	MHB4Q079B	79	3 1/8
MHB4Q024B	24	15/16	MHB4Q083B	83	3 1/4
MHB4Q025B	25	1	MHB4Q086B	86	3 3/8
MHB4Q027B	27	1 1/16	MHB4Q089B	89	3 1/2
MHB4Q029B	29	1 1/8	MHB4Q092B	92	3 5/8
MHB4Q030B	30	1 3/16	MHB4Q095B	95	3 3/4
MHB4Q032B	32	1 1/4	MHB4Q098B	98	3 7/8
MHB4Q033B	33	1 5/16	MHB4Q102B	102	4
MHB4Q035B	35	1 3/8	MHB4Q105B	105	4 1/8
MHB4Q037B	37	1 7/16	MHB4Q108B	108	4 1/4
MHB4Q038B	38	1 1/2	MHB4Q111B	111	4 3/8
MHB4Q040B	40	1 9/16	MHB4Q114B	114	4 1/2
MHB4Q041B	41	1 5/8	MHB4Q121B	121	4 3/4
MHB4Q043B	43	1 11/16	MHB4Q127B	127	5
MHB4Q044B	44	1 3/4	MHB4Q133B	133	5 1/4
MHB4Q046B	46	1 13/16	MHB4Q140B	140	5 1/2
MHB4Q048B	48	1 7/8	MHB4Q146B	146	5 3/4
MHB4Q051B	51	2	MHB4Q152B	152	6
MHB4Q052B	52	2 1/16	MHB4Q160B	160	6 5/16
MHB4Q054B	54	2 1/8	MHB4Q168B	168	6 5/8
MHB4Q057B	57	2 1/4	MHB4Q177B	177	6 31/32
MHB4Q059B	59	2 5/16	MHB4Q200B	200	7 7/8
MHB4Q060B	60	2 3/8	MHB4Q210B	210	8 1/4
MHB4Q064B	64	2 1/2			



BI-METAL FINEXCUT M42

Bi-metal Hole Saws M42 with fine vario pitched teeth for smooth cutting in thin metal sheets, thin pipes, steel, stainless steel and non-ferrous metal. The special tooth style provides a smooth cut, also on irregular surfaces.

FEATURES

- 8/12 variable teeth for clean edges
- Specifically for thin metal plate
- Bi-metal with 8% cobalt alloy for a longer lifetime
- Cutting depth 38mm (1-1/2")
- Smooth cutting with minimal heat build up
- Suitable for use in electric and battery powered tools



*To order this type of Hole Saw without MXqs adapter, replace "Q" in the Part No. with "0"

Part No.*	Ø MM	Ø INCH
MHB6Q016B	16	5/8
MHB6Q019B	19	3/4
MHB6Q020B	20	25/32
MHB6Q022B	22	7/8
MHB6Q024B	24	15/16
MHB6Q025B	25	1
MHB6Q027B	27	1 1/16
MHB6Q029B	29	1 1/8
MHB6Q030B	30	1 3/16
MHB6Q032B	32	1 1/4
MHB6Q035B	35	1 3/8
MHB6Q038B	38	1 1/2
MHB6Q040B	40	1 9/16
MHB6Q044B	44	1 3/4
MHB6Q046B	46	1 13/16
MHB6Q048B	48	1 7/8
MHB6Q051B	51	2
MHB6Q054B	54	2 1/16
MHB6Q057B	57	2 1/8
MHB6Q060B	60	2 1/4
MHB6Q064B	64	2 1/2
MHB6Q065B	65	2 9/16
MHB6Q068B	68	2 11/16
MHB6Q070B	70	2 3/4
MHB6Q073B	73	2 7/8
MHB6Q076B	76	3
MHB6Q083B	83	3 1/4
MHB6Q086B	86	3 3/8
MHB6Q089B	89	3 1/2
MHB6Q092B	92	3 5/8
MHB6Q098B	98	3 7/8
MHB6Q102B	102	4
MHB6Q108B	108	4 1/4
MHB6Q114B	114	4 1/2
MHB6Q127B	127	5



BI-METAL EASYXCUT M3

Bi-metal M3 Hole Saws with vario-pitched teeth for applications where fast cutting and low price are the main challenges. Executed with unique ejection holes for extra chip release and weight reduction. Our special tooth geometry provides the smoothest cut, requiring less feed pressure.

FEATURES

- 4/6 variable teeth for clean edges
- Smooth cutting with minimal heat build up
- Cutting depth 45mm (1-3/4") for deeper holes in one pass
- Maximum clearance of chips thanks to the wide slots
- Suitable for use in electric and battery powered tools

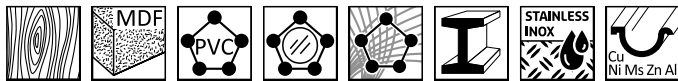

*To order this type of Hole Saw without MXqs adapter, remove the "Q" in the Part No.

Part No.*	Ø MM	Ø INCH	Part No.*	Ø MM	Ø INCH
MHB3Q0014B	14	9/16	MHB3Q0065B	65	2 9/16
MHB3Q0016B	16	5/8	MHB3Q0067B	67	2 5/8
MHB3Q0017B	17	11/16	MHB3Q0068B	68	2 11/16
MHB3Q0019B	19	3/4	MHB3Q0070B	70	2 3/4
MHB3Q0020B	20	25/32	MHB3Q0073B	73	2 7/8
MHB3Q0021B	21	13/16	MHB3Q0076B	76	3
MHB3Q0022B	22	7/8	MHB3Q0079B	79	3 1/8
MHB3Q0024B	24	15/16	MHB3Q0083B	83	3 1/4
MHB3Q0025B	25	1	MHB3Q0086B	86	3 3/8
MHB3Q0027B	27	1 1/16	MHB3Q0089B	89	3 1/2
MHB3Q0029B	29	1 1/8	MHB3Q0092B	92	3 5/8
MHB3Q0030B	30	1 3/16	MHB3Q0095B	95	3 3/4
MHB3Q0032B	32	1 1/4	MHB3Q0098B	98	3 7/8
MHB3Q0033B	33	1 5/16	MHB3Q0102B	102	4
MHB3Q0035B	35	1 3/8	MHB3Q0105B	105	4 1/8
MHB3Q0037B	37	1 7/16	MHB3Q0108B	108	4 1/4
MHB3Q0038B	38	1 1/2	MHB3Q0111B	111	4 3/8
MHB3Q0040B	40	1 9/16	MHB3Q0114B	114	4 1/2
MHB3Q0041B	41	1 5/8	MHB3Q0121B	121	4 3/4
MHB3Q0043B	43	1 11/16	MHB3Q0127B	127	5
MHB3Q0044B	44	1 3/4	MHB3Q0133B	133	5 1/4
MHB3Q0046B	46	1 13/16	MHB3Q0140B	140	5 1/2
MHB3Q0048B	48	1 7/8	MHB3Q0146B	146	5 3/4
MHB3Q0051B	51	2	MHB3Q0152B	152	6
MHB3Q0052B	52	2 1/16	MHB3Q0160B	160	6 5/16
MHB3Q0054B	54	2 1/8	MHB3Q0168B	168	6 5/8
MHB3Q0057B	57	2 1/4	MHB3Q0177B	177	6 31/32
MHB3Q0059B	59	2 5/16	MHB3Q0200B	200	7 7/8
MHB3Q0060B	60	2 3/8	MHB3Q0210B	210	8 1/4
MHB3Q0064B	64	2 1/2			

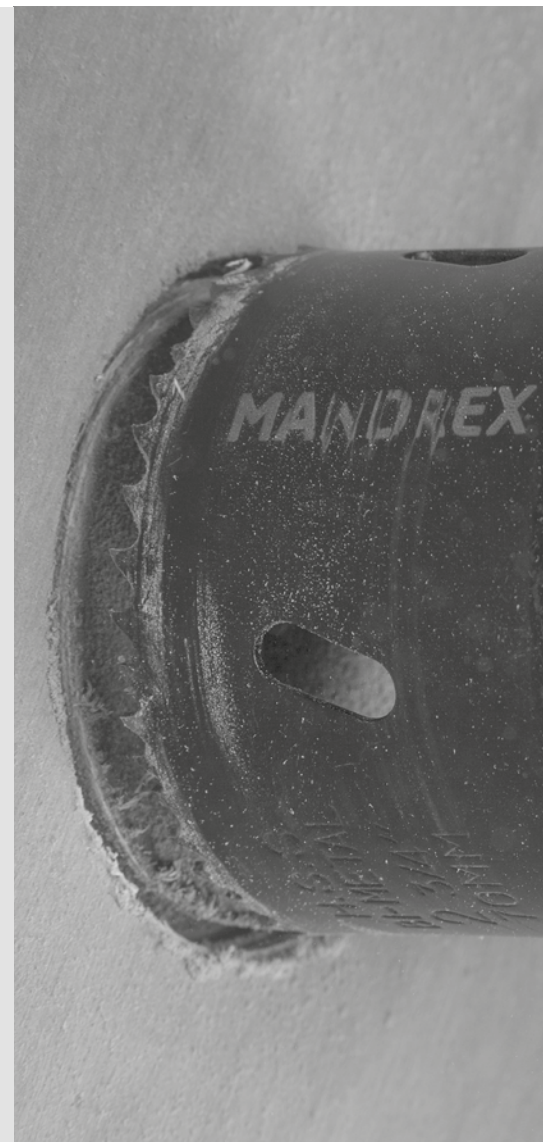

MULTI-PURPOSE SUPERXCUT XTRA DEEP 165MM

Extra-long Multi-purpose Hole Saw with unique carbide tooth set for clean and high performance cutting. With a cutting depth of 165mm, these Hole Saws are perfect for use as roof transit saws. Carbide tipped teeth made from a specially developed construction grade carbide result in outstanding cutting performance and product durability!

FEATURES

- 5 times faster and 10 times the lifetime
- Cutting depth 165mm (6-1/2") for deep drilling
- Large clearance of chips thanks to the specially designed wide slots
- Smooth cutting with minimal heat build up
- Suitable for use in electric and battery powered tools



Arbors Xtra Deep 165mm

These heavy duty arbors are suitable for use in combination with our Multi-purpose SuperXcut Xtra deep 165mm Hole Saws



MX200088HSB Arbor for 165mm Xtra deep Multi-purpose carbide tipped Hole Saws. Including extra-long HSS+ steel pilot drill MX200074B
 Drill Chuck Hex 11mm Thread 5/8"-18UNF For diameters Ø32-210mm. E.g. for wood, plywood



MX200088TCB Arbor for 165mm Xtra deep Multi-purpose carbide tipped Hole Saws. Including extra-long TCT carbide tipped pilot drill MX200075B
 Drill Chuck Hex 11mm Thread 5/8"-18UNF For diameters Ø32-210mm. E.g. for concrete, sandstone, brickwork, soft tiles

Pilot Drills Xtra Deep 165mm



MX200074B HSS+ high grade steel Xtra deep pilot drill with 135 degrees split point For use with MX200088HSB



MX200075B TCT carbide tipped Xtra deep pilot drill For use with MX200088TCB

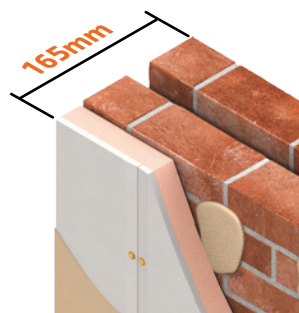

Part No.	Ø MM	Ø INCH
MHM30032B	32	1 1/4
MHM30045B	45	1 25/32
MHM30051B	51	2
MHM30060B	60	2 3/8
MHM30065B	65	2 9/16
MHM30068B	68	2 11/16
MHM30070B	70	2 3/4
MHM30080B	80	3 5/32
MHM30086B	86	3 3/8
MHM30092B	92	3 5/8
MHM30102B	102	4
MHM30111B	111	4 3/8
MHM30121B	121	4 3/4
MHM30133B	133	5 1/4
MHM30140B	140	5 1/2
MHM30152B	152	6
MHM30160B	160	6 5/16
MHM30168B	168	6 5/8
MHM30210B	210	8 1/4



MULTI-PURPOSE SUPERXCUT XTRA DEEP 165MM MXqs

Extra-long Multi-purpose Hole Saw, including the unique MXqs adapter AND also including the unique quick release MXqs arbor, with unique carbide tooth set for clean and high performance cutting. With a cutting depth of 165mm, these Hole Saws are e.g. perfect for use as roof transit saws. Carbide tipped teeth made from a specially developed construction grade carbide result in outstanding cutting performance and product durability. With the unique drilling guide pin drilling is safe and secure!

FEATURES

- 5 times faster and 10 times the lifetime compared to any competitive Hole Saw
- **Cutting depth 165mm**
- Large clearance of chips thanks to the specially designed wide slots
- Smooth cutting with minimal heat build up
- Suitable for use in electric and battery powered tools
- Drilling deep under an angle is easy when using a longer center pin*
- Extra-long side slots for easy core release

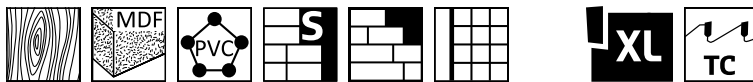

MXqs Xtra DEEP - ARBOR



MX2P1006B
MXqs Arbor
Drill Chuck Hex 11 - 7/16"PB



MX2P1006SB
MXqs Arbor
Drill Chuck SDS-Plus

MXqs Xtra DEEP - DRILLS 165 for pre-drilling

MX2P0070B Woodworking Drill (Auger Bit) For Bi-M & TCT Hole saws L=165mm
Drill Chuck Hex 11 - 7/16"PB. To drill the hole for the deep guide pin.



MX2P0072B Masonry Drill - TCT - For TCT Hole saws L=165mm
Drill Chuck Hex 11 - 7/16"PB. To drill the hole for the deep guide pin.



MX2P0074B HSS Drill L=165mm
Drill Chuck Hex 11 - 7/16"PB. To drill the hole for the deep guide pin.



MXqs Xtra DEEP - GUIDE PIN

MX200079B Guide pin - For Bi-Metal & TCT Hole saws L=165mm

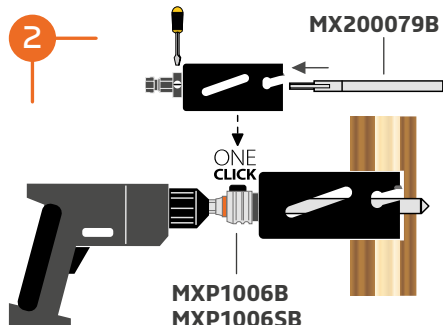
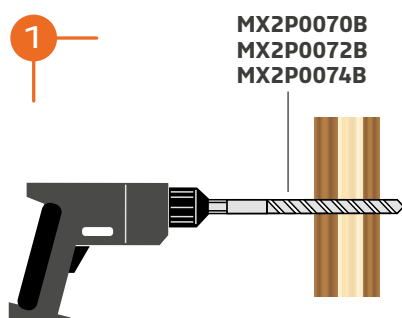

MXqs

ONE CLICK

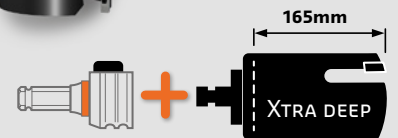
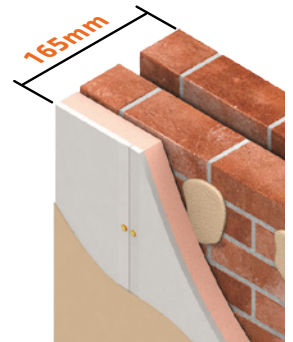

Art. No.**	Ø MM	Ø INCH
MHM30Q032B	32	1 1/4
MHM30Q045B	45	1 25/32
MHM30Q051B	51	2
MHM30Q060B	60	2 3/8
MHM30Q065B	65	2 9/16
MHM30Q068B	68	2 11/16
MHM30Q070B	70	2 3/4
MHM30Q080B	80	3 5/32
MHM30Q086B	86	3 3/8
MHM30Q092B	92	3 5/8
MHM30Q102B	102	4
MHM30Q111B	111	4 3/8
MHM30Q121B	121	4 3/4
MHM30Q133B	133	5 1/4
MHM30Q140B	140	5 1/2
MHM30Q152B	152	6
MHM30Q160B	160	6 5/16
MHM30Q168B	168	6 5/8
MHM30Q210B	210	8 1/4

**Including MXqs ONE CLICK Quick Change Arbor MX2P1006B and Adapter, excl. guide pin. Guide pin must be ordered separately.

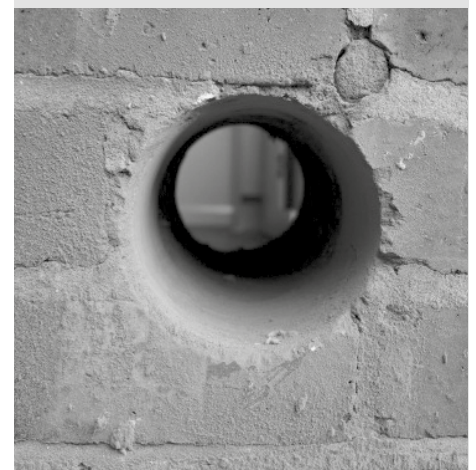

MULTI-PURPOSE SUPERXCUT XTRA DEEP 300MM MXqs

Extra-long Multi-purpose Hole Saw, including the unique MXqs adapter AND also including the unique quick release MXqs arbor, with unique carbide tooth set for clean and high performance cutting. With a cutting depth of 300mm, these Hole Saws are e.g. perfect for use as roof transit saws. Carbide tipped teeth made from a specially developed construction grade carbide result in outstanding cutting performance and product durability. With the unique drilling guide pin drilling is safe and secure!

MXqs

ONE CLICK

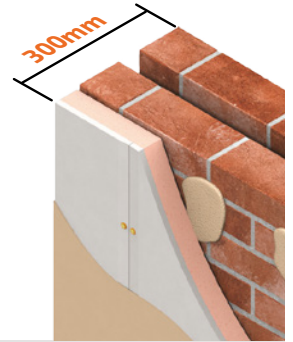

FEATURES

- 5 times faster and 10 times the lifetime compared to any competitive Hole Saw
- **Cutting depth 300mm**
- Large clearance of chips thanks to the specially designed wide slots
- Smooth cutting with minimal heat build up
- Suitable for use in electric and battery powered tools
- Drilling deep under an angle is easy when using a longer center pin*
- Extra-long side slots for easy core release

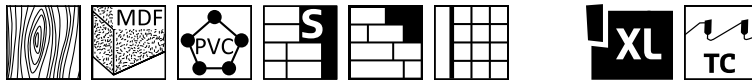

MXqs Xtra DEEP - ARBOR



MX2P1006B
MXqs Arbor
Drill Chuck Hex 11 - 7/16"PB



MX2P1006SB
MXqs Arbor
Drill Chuck SDS-Plus

MXqs Xtra DEEP - DRILLS 300 for pre-drilling

MX2P0071B Woodworking Drill (Auger Bit) For Bi-M & TCT Hole saws L=300mm
Drill Chuck Hex 11 - 7/16"PB. To drill the hole for the deep guide pin.



MX2P0073B Masonry Drill - TCT - For TCT Hole saws L=300mm
Drill Chuck Hex 11 - 7/16"PB. To drill the hole for the deep guide pin.



MX2P0075B HSS Drill L=300mm
Drill Chuck Hex 11 - 7/16"PB. To drill the hole for the deep guide pin.



MXqs Xtra DEEP - GUIDE PINS

MX200078B Guide pin - For Bi-M & TCT Hole saws L=300mm

MX200078XL Guide pin - For Bi-M & TCT Hole saws L=515mm (Pitched roofs)

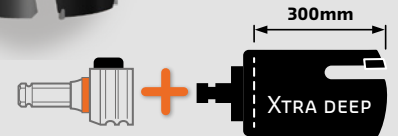
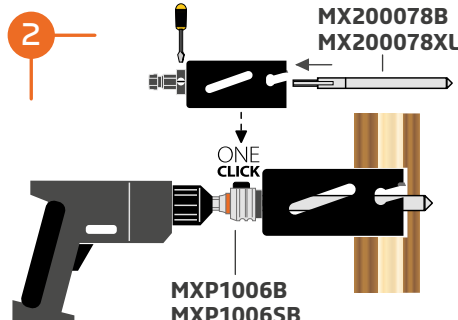
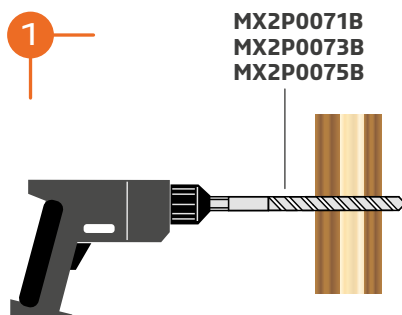

Art. No.**	Ø MM	Ø INCH
MHM31Q045B	45	1 25/32
MHM31Q060B	60	2 3/8
MHM31Q068B	68	2 11/16
MHM31Q080B	80	3 5/32
MHM31Q102B	102	4
MHM31Q111B	111	4 3/8
MHM31Q121B	121	4 3/4
MHM31Q133B	133	5 1/4
MHM31Q152B	152	6
MHM31Q168B	168	6 5/8
MHM31Q210B	210	8 1/4

**Including MXqs ONE CLICK Quick Change Arbor MX2P1006B and Adapter, excl. guide pin. Guide pins must be ordered separately.



* Drilling pitched roofs or under an angle: Pre-drill, then use a hole saw of 300mm length with a L=515 center pin.

BI-METAL SPEEDXCUT XTRA DEEP 165MM MXqs

The extra deep Bi-metal Hole Saws M42, **including the unique MXqs adapter** **AND also including the unique quick release MXqs arbor**, are especially designed to cut deep and smooth in a wide range of materials. With a cutting depth of 165mm, these hole saws are e.g. perfect for use as roof transit saws. The special tooth style provides a smooth cut, also on irregular surfaces. With the unique drilling guide pin drilling is safe and secure!

FEATURES

- Always delivered with the MXqs quick release adapter AND arbor
- Bi-metal with 8% cobalt alloy for a longer lifetime
- **Cutting depth 165mm**
- Smooth cutting with minimal heat build up
- Suitable for use in electric and battery powered tools
- Drilling deep under an angle is easy when using a longer center pin*
- Extra-long side slots for easy core release

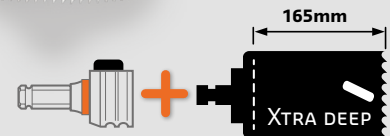
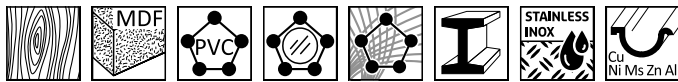

MXqs Xtra DEEP - ARBOR



MX2P1006B
MXqs Arbor
Drill Chuck Hex 11 - 7/16"PB



MX2P1006SB
MXqs Arbor
Drill Chuck SDS-Plus

MXqs Xtra DEEP - DRILLS 165 for pre-drilling

MX2P0070B Woodworking Drill (Auger Bit) For Bi-M & TCT Hole saws L=165mm
Drill Chuck Hex 11 - 7/16"PB. To drill the hole for the deep guide pin.



MX2P0074B HSS Drill For Bi-M Hole saws L=165mm
Drill Chuck Hex 11 - 7/16"PB. To drill the hole for the deep guide pin.



MXqs Xtra DEEP - GUIDE PIN

MX200079B Guide pin - For Bi-Metal & TCT Hole saws L=165mm



Part No.**	Ø MM	Ø INCH
MHM40Q044B	44	1 3/4
MHM40Q060B	60	2 3/8
MHM40Q068B	68	2 11/16
MHM40Q083B	83	3 1/4
MHM40Q102B	102	4
MHM40Q111B	111	4 3/8
MHM40Q121B	121	4 3/4
MHM40Q133B	133	5 1/4
MHM40Q152B	152	6

**Including MXqs ONE CLICK Quick Change Arbor MX2P1006B and Adapter, excl. guide pin. Guide pin must be ordered separately.

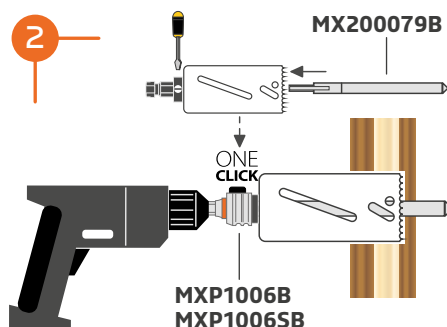
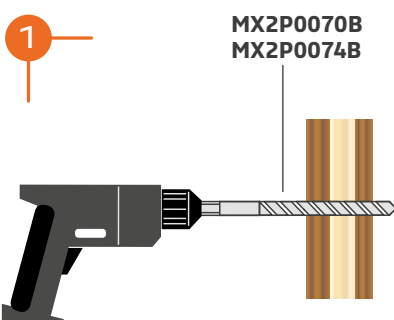

BI-METAL SPEEDXCUT XTRA DEEP 300MM MXqs

The extra deep Bi-metal Hole Saws M42, including the unique MXqs adapter AND also including the unique quick release MXqs arbor, are especially designed to cut deep and smooth in a wide range of materials. With a cutting depth of 300mm, these hole saws are e.g. perfect for use as roof transit saws. The special tooth style provides a smooth cut, also on irregular surfaces. With the unique drilling guide pin drilling is safe and secure!

FEATURES

- Always delivered with the MXqs quick release adapter AND arbor
- Bi-metal with 8% cobalt alloy for a longer lifetime
- **Cutting depth 300mm**
- Smooth cutting with minimal heat build up
- Suitable for use in electric and battery powered tools
- Drilling deep under an angle is easy when using a longer center pin*
- Extra-long side slots for easy core release

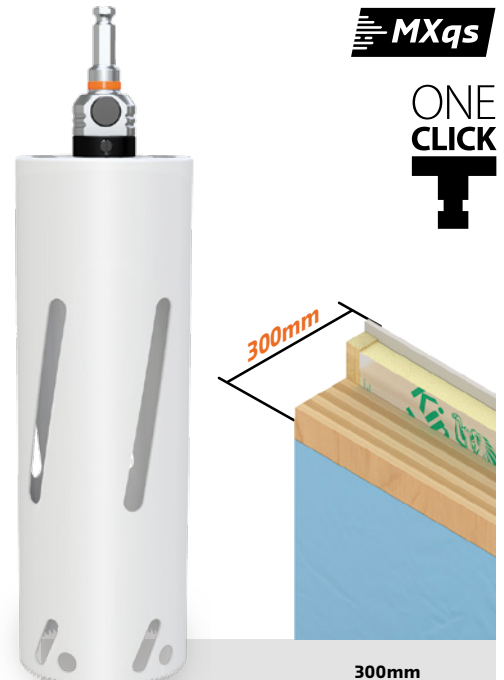
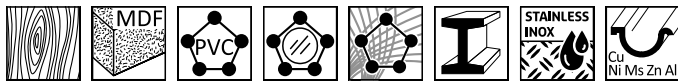

MXqs Xtra DEEP - ARBOR



MX2P1006B
MXqs Arbor
Drill Chuck Hex 11 - 7/16"PB



MX2P1006SB
MXqs Arbor
Drill Chuck SDS-Plus

MXqs Xtra DEEP - DRILLS 300 for pre-drilling

MX2P0071B Woodworking Drill (Auger Bit) For Bi-M & TCT Hole saws L=300mm
Drill Chuck Hex 11 - 7/16"PB. To drill the hole for the deep guide pin.



MX2P0075B HSS Drill For Bi-M Hole saws L=300mm
Drill Chuck Hex 11 - 7/16"PB. To drill the hole for the deep guide pin.



MXqs Xtra DEEP - GUIDE PINS

MX200078B Guide pin - For Bi-M & TCT Hole saws L=300mm

MX200078XL Guide pin - For Bi-M & TCT Hole saws L=515mm (Pitched roofs)

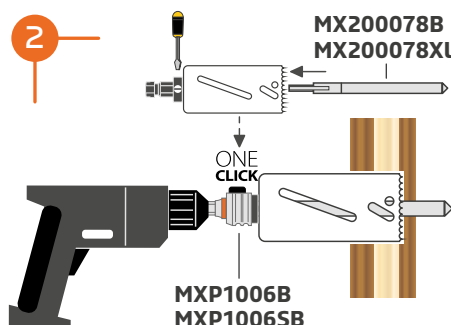
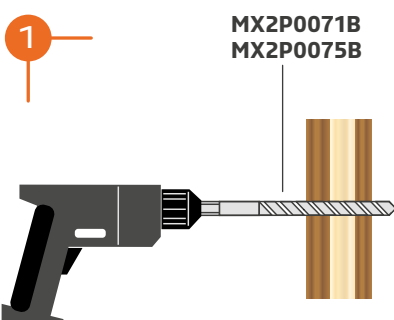

Part No.**	Ø MM	Ø INCH
MHM41Q044B	44	1 3/4
MHM41Q060B	60	2 3/8
MHM41Q068B	68	2 11/16
MHM41Q083B	83	3 1/4
MHM41Q102B	102	4
MHM41Q111B	111	4 3/8
MHM41Q121B	121	4 3/4
MHM41Q133B	133	5 1/4
MHM41Q152B	152	6

**Including MXqs ONE CLICK Quick Change Arbor MX2P1006B and Adapter, excl. guide pin. Guide pins must be ordered separately.





* Drilling pitched roofs or under an angle: Pre-drill, then use a hole saw of 300mm length with a L=515 center pin.

HOLE SAW KITS FOR EVERY JOB



Mandrex Hole Saw kits are available in professional cases which are easy to carry, and fitted with the highest quality interior. Each kit includes our Mandrex One Click Hole Saw system, spare pilot drill and hexagon key wrench.

We have created Hole Saw kits in a range of different configurations to suit every profession. No Hole Saw kit for your profession or do you just want a different content? We have integrated a production line for specialized kits, which can be produced in low quantities.

-  **INDUSTRIAL**
-  **ELECTRICIAN**
-  **PLUMBER**
-  **VENTILATION**

STARTER KITS

We have Starter Kits to introduce you to the Mandrex One Click Hole Saw System. The content selected and the professional packaging offer immediate access to its unique features.

The Starter Kits are executed with the most common Hole Saws suitable for the job, including the MXqs ONE CLICK arbor.



Part No.	ØMM	ARBOR incl. PILOT DRILL	EXTRA PILOT DRILL
ALL-PURPOSE UltraXcut (TCT)		See page 6-7	
MX200040B	73, 83	MX200024B Hex 8,5 - 11/32"PB	MX2P0062B TCT pilot drill
MX200041B	68,83	MX200024B Hex 8,5 - 11/32"PB	MX2P0062B TCT pilot drill
MX200042B	68	MX200024B Hex 8,5 - 11/32"PB	
MX200043B	60, 68, 83	MX200024B Hex 8,5 - 11/32"PB	MX2P0062B TCT pilot drill
MX200044B	76	MX200024B Hex 8,5 - 11/32"PB	MX2P0062B TCT pilot drill
MULTI-PURPOSE SuperXcut (TCT)			
MX200048B	60, 65, 80	MX200024B Hex 8,5 - 11/32"PB	MX2P0062B TCT pilot drill
MX200049B	68, 83	MX200024B Hex 8,5 - 11/32"PB	MX2P0062B TCT pilot drill
MX200050B	73, 83	MX200024B Hex 8,5 - 11/32"PB	MX2P0062B TCT pilot drill
MX200051B	68,83, Incl. MX200091B Countersink ring Ø73	MX200024B Hex 8,5 - 11/32"PB	MX2P0062B TCT pilot drill
MX200051B2	68, 74, 82	MX200020B Hex 11 - 7/16"PB	MX2P0062B TCT pilot drill
MX200052B	68	MX200024B Hex 8,5 - 11/32"PB	
MX200052B2	68, Incl. MX200091B Countersink ring Ø73	MX200020B Hex 11 - 7/16"PB	MX2P0062B TCT pilot drill
MX200053B	60, 68, 80	MX200024B Hex 8,5 - 11/32"PB	MX2P0062B TCT pilot drill
MX200053B2	60, 68, 82	MX200020B Hex 11 - 7/16"PB	MX2P0062B TCT pilot drill
MX200054B	67	MX200024B Hex 8,5 - 11/32"PB	
MX200056B	76	MX200024B Hex 8,5 - 11/32"PB	MX2P0062B TCT pilot drill
MX200057B	65, 83	MX200024B Hex 8,5 - 11/32"PB	MX2P0062B TCT pilot drill
MX200058B	65	MX200024B Hex 8,5 - 11/32"PB	MX2P0062B TCT pilot drill
BI-METAL SpeedXcut M42			
MX200060B	73, 83	MX200024B Hex 8,5 - 11/32"PB	MX2P0063B HSS pilot drill
MX200061B	68, 83	MX200024B Hex 8,5 - 11/32"PB	MX2P0063B HSS pilot drill
MX200062B	68	MX200024B Hex 8,5 - 11/32"PB	MX2P0063B HSS pilot drill
MX200063B	60, 68, 83	MX200024B Hex 8,5 - 11/32"PB	MX2P0063B HSS pilot drill
MX200064B	68	MX200024B Hex 8,5 - 11/32"PB	
MX200065B	67	MX200024B Hex 8,5 - 11/32"PB	MX2P0063B HSS pilot drill
MX200066B	76	MX200024B Hex 8,5 - 11/32"PB	MX2P0063B HSS pilot drill

Starter Kits - MXqs Arbors

All starterkits included:
2x adapters 1/2" for Hole Saws Ø14-30mm AND 3x adapters 5/8" for Hole Saws Ø32-210mm

Part No.	ARBOR incl. PILOT DRILL
MX200030B	MX200020B Hex 11 - 7/16"PB with 125mm HSS pilot drill
MX200031B	MX200022B Hex 11 - 7/16"PB with 105mm HSS pilot drill*
MX200032B	MX200024B Hex 8,5 - 11/32"PB with 125mm HSS pilot drill
MX200033B	MX200026B Hex 8,5 - 11/32"PB with 105mm HSS pilot drill*
MX200034B	MX200020SB SDS plus with 125mm HSS pilot drill
MX200035B	MX200022SB SDS plus with 105mm HSS pilot drill*

* Arbors with short pilot drills can be used in combination with short Hole Saws (cutting depth 38mm)



ALL-PURPOSE ULTRACUT KITS

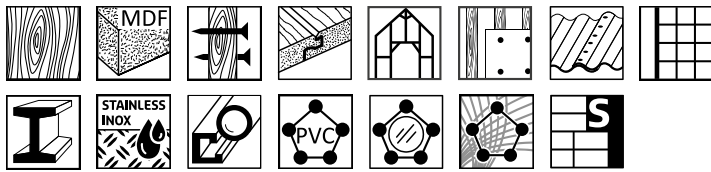

MXqs

**ONE
CLICK**



Part No.	ØMM	Ø INCH	ARBOR incl. PILOT DRILL	EXTRA PILOT DRILL
⚡ ELECTRICIAN				
See page 6-7				
MHSE1006	22, 27, 35, 44, 51, 70, 73, 95	7/8, 1-1/16, 1-3/8, 1-3/4, 2, 2-3/4, 2-7/8, 3-7/8	MX200024B	MX2P0062B
MHSE1006A	20, 25, 32, 38, 51, 73	25/32, 1, 1-1/4, 1-1/2, 2, 2-7/8	MX200024B	MX2P0062B
MHSE1006B	19, 25, 38, 44, 68, 83	3/4, 1, 1-1/2, 1-3/4, 2-11/16, 3-1/4	MX200024B	MX2P0062B
MHSE1006C	19, 22, 25, 35, 41, 51, 64, 76, 83	3/4, 7/8, 1, 1 3/8, 1 5/8, 2, 2 1/2, 3, 3 1/4	MX200024B	MX2P0062B
MHSE1006D	19, 22, 25, 30, 35, 41, 44, 51, 64, 76, 83	3/4, 7/8, 1, 1 3/16, 1 3/8, 1 5/8, 1 3/4, 2, 2 1/2, 3, 3 1/4	MX200024B	MX2P0062B
MHSE1006E	57, 64, 68, 79, 83	2-1/4, 2-1/2, 2-11/16, 3-1/8, 3-1/4	MX200024B	MX2P0062B
⚙ INDUSTRIAL				
MHSD1006	19, 22, 25, 29, 35, 38, 44, 51, 57, 64, 76	3/4, 7/8, 1, 1-1/8, 1-3/8, 1-1/2, 1-3/4, 2, 2-1/4, 2-1/2, 3	MX200020B	MX2P0062B
MHSD1006A	19, 22, 25, 32, 35, 38, 44, 51, 57, 68, 76	3/4, 7/8, 1, 1-1/4, 1-3/8, 1-1/2, 1-3/4, 2, 2-1/4, 2-11/16, 3	MX200020B	MX2P0062B
MHSD1006B	22, 30, 35, 44, 51, 64, 76, 95, 105	7/8, 1-3/16, 1-3/8, 1-3/4, 2, 2-1/2, 3, 3-3/4, 4-1/8	MX200024B	MX2P0062B
MHSD1006C	20, 22, 25, 32, 35, 41, 44, 51, 60, 68, 76	25/32, 7/8, 1, 1-1/4, 1-3/8, 1-5/8, 1-3/4, 2, 2-3/8, 2-11/16, 3	MX200024B	MX2P0062B
MHSD1006D	25, 32, 41, 54, 60, 68, 76, 83	1, 1-1/4, 1-5/8, 2-1/8, 2-3/8, 2-11/16, 3, 3-1/4	MX200024B	MX2P0062B
🔧 PLUMBER				
MHSP1006	19, 22, 29, 38, 44, 57	3/4, 7/8, 1-1/8, 1-1/2, 1-3/4, 2-1/4	MX200020B	MX2P0062B
MHSP1006A	20, 25, 32, 41, 48, 57	25/32, 1, 1-1/4, 1-5/8, 1-7/8, 2-1/4	MX200020B	MX2P0062B
MHSP1006B	19, 25, 30, 35, 41, 68	3/4, 1, 1-3/16, 1-3/8, 1-5/8, 2-11/16	MX200024B	MX2P0062B
MHSP1006C	57, 64, 76, 92, 114	2-1/4, 2-1/2, 3, 3-5/8, 4-1/2"	MX200024B	MX2P0062B



MULTI-PURPOSE SUPERXCUT KITS

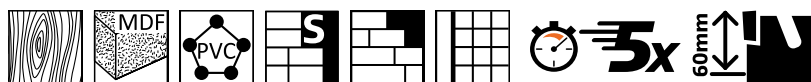

Part No.	ØMM	Ø INCH	ARBOR incl. PILOT DRILL	EXTRA PILOT DRILL
ELECTRICIAN				
See page 6-7				
MHSE1001	22, 29, 35, 44, 51, 64	7/8, 1-1/8, 1-3/8, 1-3/4, 2, 2-1/2	MX200020B	MX2P0062B
MHSE1001A	60, 73, 76, 83, 86, 102	2-3/8, 2-7/8, 3, 3-1/4, 3-3/8, 4	MX200024B	MX2P0062B
MHSE1001A2	30, 40, 57, 60, 65, 68, 80, 86	1-3/16, 1-9/16, 2-1/4, 2-3/8, 2-9/16, 2-11/16, 3-5/32, 3-3/8	MX200020B	MX2P0062B
MHSE1001B	19, 22, 27, 35, 44, 54, 70, 73, 83	3/4, 7/8, 1-1/16, 1-3/8, 1-3/4, 2-1/8, 2-3/4, 2-7/8, 3-1/4	MX200024B	MX2P0062B
MHSE1001B2	35, 50, 57, 60, 68, 80 MX200091B Countersink ring Ø73	1-3/8, 1-31/32, 2-1/4, 2-3/8, 3-5/32	MX200020B	MX2P0062B
MHSE1001C	16, 20, 24, 29, 37, 68, 70, 73	5/8, 25/32, 15/16, 1-1/8, 1-7/16, 2-11/16, 2-3/4, 2-7/8	MX200024B	MX2P0062B
MHSE1001C2	35, 44, 51, 60, 68, 80	1-3/8, 1-3/4, 2, 2-3/8, 2-11/16, 3-5/32	MX200020B	MX2P0062B
MHSE1001D	22, 32, 35, 44, 51, 57, 60, 68, 76, 83 MX200091B Countersink ring Ø73	7/8, 1-1/4, 1-3/8, 1-3/4, 2, 2-1/4, 2-3/8, 2-11/16, 3, 3-1/4	MX200020B	MX2P0062B
MHSE1001D2	35, 44, 51, 60, 68, 82	1-3/8, 1-3/4, 2, 2-3/8, 2-11/16, 3-15/64	MX200020B	MX2P0062B
MHSE1001E	16, 20, 25, 29, 44, 51	5/8, 25/32, 1, 1-1/8, 1-3/4, 2	MX200024B	MX2P0062B
MHSE1001F	22, 29, 35, 44, 51, 64, 68	7/8, 1-1/8, 1-3/8, 1-3/4, 2, 2-1/2, 2-11/16	MX200020B	MX2P0062B
MHSE1001G	16, 19, 22, 25, 29, 32, 35, 38, 44, 51, 64, 68	5/8, 3/4, 7/8, 1, 1-1/8, 1-1/4, 1-3/8, 1-1/2, 1-3/4, 2, 2-1/2, 2-11/16	MX200020B	MX2P0062B
MHSE1001H	25, 29, 35, 44, 68, 76, 105	1, 1-1/8, 1-3/8, 1-3/4, 2-11/16, 3, 4-1/8	MX200024B	MX2P0062B
MHSE1001J	40, 54, 68, 73, 86	1-9/16, 2-1/8, 2-11/16, 2-7/8, 3-3/8	MX200024B	MX2P0062B
MHSE1001K	22, 27, 35, 43, 52, 70, 73, 95	7/8, 1-1/16, 1-3/8, 1-11/16, 2-1/16, 2-3/4, 2-7/8, 3-7/8	MX200024B	MX2P0062B
MHSE1001L	22, 29, 35, 44, 51, 64	7/8, 1-1/8, 1-3/8, 1-3/4, 2, 2-1/2	MX200024B	MX2P0062B
MHSE1001M	16, 20, 25, 32, 40, 51	5/8, 25/32, 1, 1-1/4, 1-9/16, 2	MX200024B	MX2P0062B
MHSE1001N	16, 20, 22, 25, 29, 35, 44, 51, 64, 68, 76	5/8, 25/32, 7/8, 1, 1-1/8, 1-3/8, 1-3/4, 2, 2-1/2, 2-11/16, 3	MX200024B	MX2P0062B
MHSE1001P	16, 19, 22, 29, 35, 44, 51, 56, 68, 73, 76 MX2P0052HEB Hole Enlargement	5/8, 3/4, 7/8, 1-1/8, 1-3/8, 1-3/4, 2, 2-3/16, 2-11/16, 2-7/8, 3	MX200024B	MX2P0062B MX2P0063B
MHSE1001Q	17, 21, 25, 33, 41, 51, 65, 76, 83	11/16, 13/16, 1, 1-5/16, 1-5/8, 2, 2-9/16, 3, 3-1/4	MX200024B	MX2P0062B
MHSE1001R	19, 25, 38, 44, 68, 83	3/4, 1, 1-1/2, 1-3/4, 2-11/16, 3-1/4	MX200024B	MX2P0062B
MHSE1001S	19, 25, 30, 35, 40, 68	3/4, 1, 1-3/16, 1-3/8, 1-9/16, 2-11/16	MX200024B	MX2P0062B
MHSE1001T	22, 25, 35, 40, 51, 68	7/8, 1, 1-3/8, 1-9/16, 2, 2-11/16	MX200024B	MX2P0062B
MHSE1001V	20, 25, 32, 40, 51, 64	25/32, 1, 1-1/4, 1-9/16, 2, 2-1/2	MX200020B	MX2P0062B
MHSE1001W	22, 29, 35, 44, 51, 68	7/8, 1-1/8, 1-3/8, 1-3/4, 2, 2-11/16	MX200020B	MX2P0062B
MHSE1001X	22, 27, 35, 38, 44, 51, 68, 76	7/8, 1-1/16, 1-3/8, 1-1/2, 1-3/4, 2, 2-11/16, 3	MX200020B	MX2P0062B
MHSE1001Y	25, 35, 44, 60, 68, 80	1, 1-3/8, 1-3/4, 2-3/8, 2-11/16, 3-5/32	MX200020B	MX2P0062B
MHSE1001Z	25, 35, 46, 56, 68, 82	1, 1-3/8, 1-13/16, 2-3/16, 2-11/16, 3-15/64	MX200020B	MX2P0062B
INDUSTRIAL				
MHSD1001	19, 22, 25, 29, 35, 38, 44, 51, 57, 64, 76	3/4, 7/8, 1, 1-1/8, 1-3/8, 1-1/2, 1-3/4, 2, 2-1/4, 2-1/2, 3	MX200020B	MX2P0062B
MHSD1001A	22, 30, 35, 44, 51, 64, 76, 95, 105	7/8, 1-3/16, 1-3/8, 1-3/4, 2, 2-1/2, 3, 3-3/4, 4-1/8	MX200024B	MX2P0062B
MHSD1001B	19, 22, 25, 32, 35, 38, 44, 51, 57, 64, 76	3/4, 7/8, 1, 1-1/4, 1-3/8, 1-1/2, 1-3/4, 2, 2-1/4, 2-1/2, 3	MX200024B	MX2P0062B
MHSD1001C	19, 25, 35, 40, 51, 56, 64, 68, 76 MX2P0052HEB Hole Enlargement	3/4, 1, 1-3/8, 1-9/16, 2, 2-3/16, 2-1/2, 2-11/16, 3	MX200024B	MX2P0062B
MHSD1001D	22, 57, 65, 68, 73, 79 MX2P0052HEB Hole Enlargement	7/8, 2-1/4, 2-9/16, 2-11/16, 2-7/8, 3-1/8	MX200024B	MX2P0062B
MHSD1001E	57, 65, 68, 76, 83	2-1/4, 2-9/16, 2-11/16, 3, 3-1/4	MX200024B	MX2P0062B
MHSD1001F	59, 65, 76, 92, 114	2-5/16, 2-9/16, 3, 3-5/8, 4-1/2	MX200024B	MX2P0062B
MHSD1001G	20, 22, 25, 32, 35, 40, 44, 51, 60, 68, 76	25/32, 7/8, 1, 1-1/4, 1-3/8, 1-9/16, 1-3/4, 2, 2-3/8, 2-11/16, 3	MX200024B	MX2P0062B
MHSD1001H	25, 32, 40, 54, 60, 68, 76, 86	1, 1-1/4, 1-9/16, 2-1/8, 2-3/8, 2-11/16, 3, 3-3/8	MX200024B	MX2P0062B
PLUMBER				
MHSP1001	19, 22, 29, 38, 44, 57	3/4, 7/8, 1-1/8, 1-1/2, 1-3/4, 2-1/4	MX200020B	MX2P0062B
MHSP1001A	29, 32, 35, 41, 51, 76, 114	1-1/8, 1-1/4, 1-3/8, 1-5/8, 2, 3, 4-1/2	MX200020B	MX2P0062B
MHSP1001B	SuperXcut: 16, 22, 35, 57, 65, 92, 127 FineXcut M42: 35	SuperXcut: 5/8, 7/8, 1-3/8, 2-1/4, 2-9/16, 3-5/8, 4-1/2 FineXcut M42: 1-3/8	MX200020B	MX2P0062B
MHSP1001C	20, 24, 32, 44, 57, 79	25/32, 15/16, 1-1/4, 1-3/4, 2-1/4, 3-1/8	MX200024B	MX2P0062B
MHSP1001D	19, 22, 29, 38, 44, 51, 57	3/4, 7/8, 1-1/8, 1-1/2, 1-3/4, 2, 2-1/4	MX200024B	MX2P0062B
MHSP1001E	57, 64, 76, 92, 114	2-1/4, 2-1/2, 3, 3-5/8, 4-1/2	MX200020B	MX2P0062B
VENTILATION				
MHSV1001	57, 111, 133, 168, 210	2-1/4, 4-3/8, 5-1/4, 6-5/8, 8-1/4	MX200020B	MX2P0062B
MHSV1001A	108, 133, 168, 210	4-1/4, 5-1/4, 6-5/8, 8-1/4	MX200020B MX200020SB	MX2P0062B MX2P0063B

BI-METAL SPEEDXCUT M42 KITS

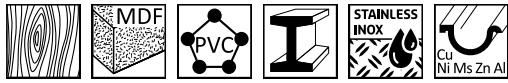

MXqs

ONE
CLICK



Part No.	ØMM	Ø INCH	ARBOR incl. PILOT DRILL	EXTRA PILOT DRILL
ELECTRICIAN			See page 6-7	
MHSE1003	22, 29, 35, 44, 51, 64	7/8, 1-1/8, 1-3/8, 1-3/4, 2, 2-1/2	MX200020B	MX2P0063B
MHSE1003A	16, 20, 25, 29, 44, 51	5/8, 25/32, 1, 1-1/8, 1-3/4, 2	MX200024B	MX2P0063B
MHSE1003B	19, 22, 27, 35, 44, 54, 70, 73, 83	3/4, 7/8, 1-1/16, 1-3/8, 1-3/4, 2-1/8, 2-3/4, 2-7/8, 3-1/4	MX200020B	MX2P0063B
MHSE1003C	22, 29, 35, 44, 51, 64, 68	7/8, 1-1/8, 1-3/8, 1-3/4, 2, 2-1/2, 2-11/16	MX200020B	MX2P0063B
MHSE1003D	16, 19, 22, 25, 29, 32, 35, 38, 44, 51, 64, 68	5/8, 3/4, 7/8, 1, 1-1/8, 1-1/4, 1-3/8, 1-1/2, 1-3/4, 2, 2-1/2, 2-11/16	MX200020B	MX2P0063B
MHSE1003E	22, 27, 35, 43, 52, 70, 73, 95	7/8, 1-1/16, 1-3/8, 1-11/16, 2-1/16, 2-3/4, 2-7/8, 3-7/8	MX200024B	MX2P0063B
MHSE1003F	60, 73, 76, 83, 86, 102	2-3/8, 2-7/8, 3-3/4, 3-3/8, 4	MX200024B	MX2P0063B
MHSE1003G	22, 32, 57, 73, 102	7/8, 1-1/4, 2-1/4, 2-7/8, 4	MX200024B	MX2P0063B
MHSE1003H	20, 25, 32, 38, 51, 73	25/32, 1, 1-1/4, 1-1/2, 2, 2-7/8	MX200024B	MX2P0063B
MHSE1003J	20, 25, 32, 40, 51, 64 MX2P0052HEB Hole Enlargement	25/32, 1, 1-1/4, 1-9/16, 2, 2-1/2	MX200024B	MX2P0063B
MHSE1003K	19, 25, 38, 44, 68, 83	3/4, 1, 1-1/2, 1-3/4, 2-11/16, 3-1/4	MX200024B	MX2P0063B
MHSE1003L	19, 25, 30, 35, 40, 68	4/4, 1, 1-3/16, 1-3/8, 1-9/16, 2-11/16	MX200024B	MX2P0063B
MHSE1003M	22, 25, 35, 40, 51, 68	7/8, 1, 1-3/8, 1-9/16, 2, 2-11/16	MX200024B	MX2P0063B
MHSE1003N	22, 29, 38, 44, 57, 67	7/8, 1-1/8, 1-1/2, 1-3/4, 2-1/4, 2-5/8	MX200020B	MX2P0063B
MHSE1003P	20, 25, 32, 70, 76, 86 MX2P0052HEB Hole Enlargement	25/32, 1, 1-1/4, 2-3/4, 3, 3-3/8	MX200020B	MX2P0063B
INDUSTRIAL				
MHSD1003	19, 22, 25, 29, 35, 38, 44, 51, 57, 64, 76	3/4, 7/8, 1, 1-1/8, 1-3/8, 1-1/2, 1-3/4, 2, 2-1/4, 2-1/2, 3	MX200020B	MX2P0063B
MHSD1003A	19, 22, 25, 32, 35, 38, 44, 51, 57, 68, 76	3/4, 7/8, 1, 1-1/4, 1-3/8, 1-1/2, 1-3/4, 2, 2-1/4, 2-11/16, 3	MX200020B	MX2P0063B
MHSD1003B	22, 30, 35, 44, 51, 64, 76, 95, 105	7/8, 1-3/16, 1-3/8, 1-3/4, 2, 2-1/2, 3, 3-3/4, 4-1/8	MX200024B	MX2P0063B
MHSD1003C	14, 20, 35, 54, 133	9/16, 25/32, 1-3/8, 2-1/8, 5-1/4	MX200024B	MX2P0063B
MHSD1003D	20, 22, 25, 32, 35, 40, 44, 51, 60, 68, 76	25/32, 7/8, 1, 1-1/4, 1-3/8, 1-9/16, 1-3/4, 2, 2-3/8, 2-11/16, 3	MX200024B	MX2P0063B
MHSD1003E	25, 32, 40, 54, 60, 68, 76, 86	1, 1-1/4, 1-9/16, 2-1/8, 2-3/8, 2-11/16, 3, 3-3/8	MX200024B	MX2P0063B
MHSD1003F	17, 21, 25, 33, 41, 51, 65, 76, 83	11/16, 13/16, 1, 1-5/16, 1-5/8, 2, 2-9/16, 3, 3-1/4	MX200024B	MX2P0063B
PLUMBER				
MHSP1003	19, 22, 29, 38, 44, 57	3/4, 7/8, 1-1/8, 1-1/2, 1-3/4, 2-1/4	MX200020B	MX2P0063B
MHSP1003A	20, 24, 32, 44, 57, 79	25/32, 15/16, 1-1/4, 1-3/4, 2-1/4, 3-1/8	MX200024B	MX2P0063B
MHSP1003B	20, 25, 32, 40, 48, 57	25/32, 1, 1-1/4, 1-9/16, 1-7/8, 2-1/4	MX200020B	MX2P0063B
VENTILATION				
MHSV1003	57, 111, 133, 168, 210	2-1/4, 4-3/8, 5-1/4, 6-5/8, 8-1/4	MX200020B	MX2P0063B

SUPERXCUT + SPEEDXCUT M42 KIT



MXqs

ONE
CLICK



Part No.	ØMM	Ø INCH	ARBOR incl. PILOT DRILL	EXTRA PILOT DRILL
ELECTRICIAN			See page 6-7	
MHSE1005	MP TCT: 35, 68, 76, 83 Bi-metal M42: 35, 68, 76, 83 MX200091B Countersink ring Ø73	MP TCT: 1-3/8, 2-11/16, 3, 3-1/4 Bi-metal M42: 1-3/8, 2-11/16, 3, 3-1/4 MX200091B Countersink ring Ø2-7/8"	MX200020B	MX2P0062B MX2P0063B

BI-METAL FINEXCUT M42 KITS



MXqs

ONE
CLICK



Part No.	ØMM	Ø INCH	ARBOR incl. PILOT DRILL	EXTRA PILOT DRILL
ELECTRICIAN			See page 6-7	
MHSE1004	22, 29, 35, 44, 51, 64	7/8, 1-1/8, 1-3/8, 1-3/4, 2, 2-1/2	MX200020B	MX2P0063B
INDUSTRIAL				
MHSD1004	19, 22, 25, 29, 35, 38, 44, 51, 57, 64, 76	3/4, 7/8, 1, 1-1/8, 1-3/8, 1-1/2, 1-3/4, 2, 2-1/4, 2-1/2, 3	MX200020B	MX2P0063B
PLUMBER				
MHSP1004	19, 22, 29, 38, 44, 57	3/4, 7/8, 1-1/8, 1-1/2, 1-3/4, 2-1/4	MX200020B	MX2P0063B

BI-METAL EasyXCUT M3 KITS



MXqs





ONE
CLICK



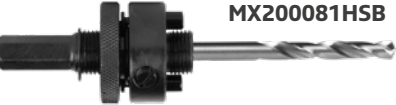
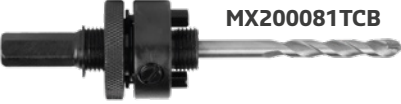

Part No.	ØMM	Ø INCH	ARBOR incl. PILOT DRILL	EXTRA PILOT DRILL
ELECTRICIAN			See page 6-7	
MHSE1002	22, 29, 35, 44, 51, 64	7/8, 1-1/8, 1-3/8, 1-3/4, 2, 2-1/2	MX200020B	MX2P0063B
MHSE1002A	22, 27, 35, 43, 52, 70, 73, 95	7/8, 1-1/16, 1-3/8, 1-11/16, 2-1/16, 2-3/4, 2-7/8, 3-7/8	MX200024B	MX2P0063B
MHSE1002B	20, 25, 32, 40, 48, 51, 65, 83	25/32, 1, 1-1/4, 1-9/16, 1-7/8, 2, 2-9/16, 3-1/4	MX200024B	MX2P0063B
MHSE1002C	19, 25, 38, 44, 68, 83	3/4, 1, 1-1/2, 1-3/4, 2-11/16, 3-1/4	MX200024B	MX2P0063B
MHSE1002D	19, 25, 30, 35, 40, 68	3/4, 1, 1-3/16, 1-3/8, 1-9/16, 2-11/16	MX200024B	MX2P0063B
MHSE1002E	22, 25, 35, 40, 51, 68	7/8, 1, 1-3/8, 1-9/16, 2, 2-11/16	MX200024B	MX2P0063B
INDUSTRIAL				
MHSD1002	19, 22, 25, 29, 35, 38, 44, 51, 57, 64, 76	3/4, 7/8, 1, 1-1/8, 1-3/8, 1-1/2, 1-3/4, 2, 2-1/4, 2-1/2, 3	MX200020B	MX2P0063B
MHSD1002A	22, 30, 35, 44, 51, 64, 76, 95, 105	7/8, 1-3/16, 1-3/8, 1-3/4, 2, 2-1/2, 3, 3-3/4, 4-1/8	MX200024B	MX2P0063B
MHSD1002B	20, 22, 25, 32, 35, 40, 44, 51, 60, 68, 76	25/32, 7/8, 1, 1-1/4, 1-3/8, 1-9/16, 1-3/4, 2, 2-3/8, 2-11/16, 3	MX200024B	MX2P0063B
MHSD1002C	25, 32, 40, 54, 60, 68, 76, 86	1, 1-1/4, 1-9/16, 2-1/8, 2-3/8, 2-11/16, 3, 3-3/8	MX200024B	MX2P0063B
PLUMBER				
MHSP1002	19, 22, 29, 38, 44, 57	3/4, 7/8, 1-1/8, 1-1/2, 1-3/4, 2-1/4	MX200020B	MX2P0063B

ARBORS

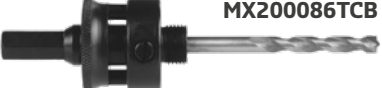

These heavy duty, carbon steel arbors are available in combination with HSS or Tungsten carbide tipped pilot drills. Suitable for use in electric and battery powered tools.

	MX200082HSB Arbor for Multi-purpose carbide tipped and Bi-metal Hole Saws. Including HSS Pilot drill MX200070B	Drill Chuck Hex 11mm With thread 1/2"-20UNF for Hole Saw diameters Ø14-30mm. E.g. for wood, plastics, steel, stainless
	MX200082TCB Arbor for Multi-purpose carbide tipped Hole Saws. Including carbide tipped pilot drill MX200073B	Drill Chuck Hex 11mm With thread 1/2"-20UNF for Hole Saw diameters Ø14-30mm. E.g. for concrete, sandstone, brickwork, soft tiles
	MX200081HSB "Quick Turn-Lock" arbor for Multi-purpose carbide tipped and Bi-metal Hole Saws. Including HSS Pilot drill MX200070B	Drill Chuck Hex 11mm With thread 5/8"-18UNF for Hole Saw diameters Ø32-210mm. E.g. for wood, plastics, steel, stainless
	MX200081TCB "Quick Turn-Lock" arbor for Multi-purpose carbide tipped Hole Saws. Including HSS Pilot drill MX200071B	Drill Chuck Hex 11mm With thread 5/8"-18UNF for Hole Saw diameters Ø32-210mm. E.g. for concrete, sandstone, brickwork, soft tiles
	MX200086HSB "Quick Pull" arbor for Multi-purpose carbide tipped and Bi-metal Hole Saws. Including HSS Pilot drill MX200070B	Drill Chuck Hex 11mm With thread 5/8"-18UNF for Hole Saw diameters Ø32-210mm. E.g. for wood, plastics, steel, stainless
	MX200086TCB Quick Pull" arbor for Multi-purpose carbide tipped. Including HSS Pilot drill MX200071B	Drill Chuck Hex 11mm With thread 5/8"-18UNF for Hole Saw diameters Ø32-210mm. E.g. for concrete, sandstone, brickwork, soft tiles

PILOT DRILLS

	MX200070B Pilot drill from HSS+ high grade steel with 135 degrees split point For use with MX200081HSB / MX200086HSB
	MX200071B Pilot drill with TCT tungsten carbide tipped point For use with MX200081TSB / MX200086TCB
	MX200073B Pilot drill with TCT tungsten carbide tipped point For use with MX200082TSB

ADAPTERS & EXTENSIONS

	MX200084B Hole Saw thread adapter. Use your Hole Saw Ø32-210mm with 5/8"-18UNF thread also on the small arbors MX200082HSB / MX200082TCB with thread 1/2"-20UNF. 3 Pieces/package
	MX200087B Extend the hole depth with 300mm. For use with Hex. 11 - 7/16" arbors.
	MX200089B Extend the hole depth with 300mm. For use with Hex. 8,5 - 11/32" arbors.

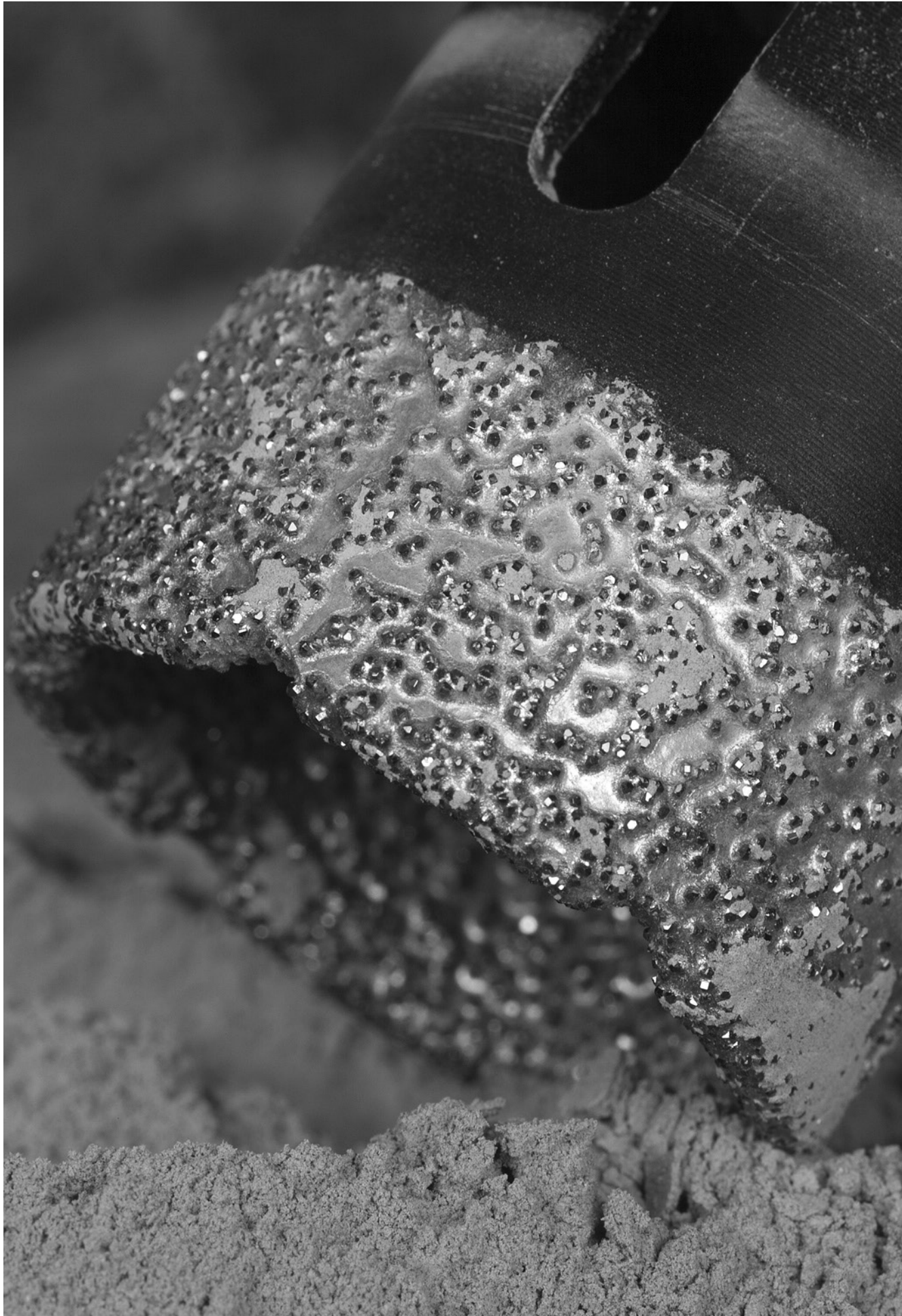

DIAMOND ProXCUT

Thanks to the brazed diamond edge, it cuts holes faster than any diamond grit or carbide tipped Hole Saw. The diamond layer ensures a long lifetime, even when drilling in the hardest materials.

If used in combination with the unique ProXcut Center Drill (page 29) there is low risk for slipping.

FEATURES

- Clean edges and accurate cuts
- Ideal for tiles, granite and hard and natural stone (e.g. marble)
- Side holes for release of slurry
- Cutting depth is 38mm (1-1/2")
- Reduced risk of slipping with the unique ProXcut Center Drill
- Extra fine diamond cutting edge for fast and clean cutting
- Wet and dry drilling, minimal water required
- Suitable for low speed electric and battery powered drilling machines

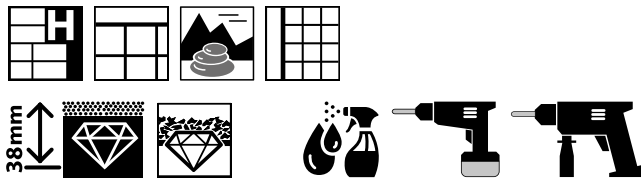

*To order this type of diamond Hole Saw without MXqs adapter, change the "Q" in the Part No. for "O". Diamond ProXcut Hole Saws without MXqs adapters have 1/2" & 5/8" thread as regular Hole Saws.



Part No.*	Ø MM	Ø INCH
MHD4Q019B	19	3/4
MHD4Q020B	20	25/32
MHD4Q022B	22	7/8
MHD4Q025B	25	1
MHD4Q029B	29	1 1/8
MHD4Q032B	32	1 1/4
MHD4Q035B	35	1 3/8
MHD4Q038B	38	1 1/2
MHD4Q041B	41	1 5/8
MHD4Q044B	44	1 3/4
MHD4Q048B	48	1 7/8
MHD4Q051B	51	2
MHD4Q054B	54	2 1/8
MHD4Q057B	57	2 1/4
MHD4Q060B	60	2 3/8
MHD4Q064B	64	2 1/2
MHD4Q065B	65	2 9/16
MHD4Q068B	68	2 11/16
MHD4Q073B	73	2 7/8
MHD4Q076B	76	3
MHD4Q079B	79	3 1/8
MHD4Q083B	83	3 1/4
MHD4Q092B	92	3 5/8
MHD4Q102B	102	4
MHD4Q114B	114	4 1/2

MXqs Diamond ARBORS

	MX2P1006B MXqs Arbor Drill Chuck Hex 11 - 7/16"PB	
	MX2P1007B MXqs Arbor Drill Chuck Hex 8,5 - 11/32"PB	
	MX2P1006SB MXqs Arbor SDS-PLUS Drill Chuck SDS-plus	

MXqs ProXCUT ADAPTER

	MXQDA001B MXqs ONE CLICK adapter only to use with ProXcut diamond hole saws 1/2"-20UNC 3 Pieces/package
	MXQDA002B MXqs ONE CLICK adapter only to use with ProXcut diamond hole saws 5/8"-18UNC 3 Pieces/package



MXqs DIAMOND WITH THE MOST STABLE ProXcut PILOT DRILL

Accurate positioning and stable drilling with the unique ProXcut center drill.

Besides the benefits of the Mandrex MXqs ONE CLICK arbor system, the ProXcut center drill has been developed to make your work easier and safer. The ProXcut center drill lowers the risk of slipping and raises the accuracy of positioning.

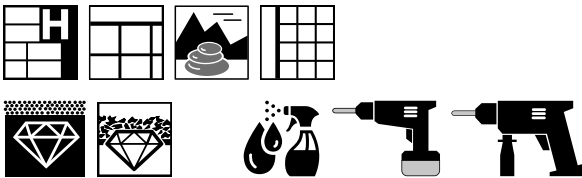
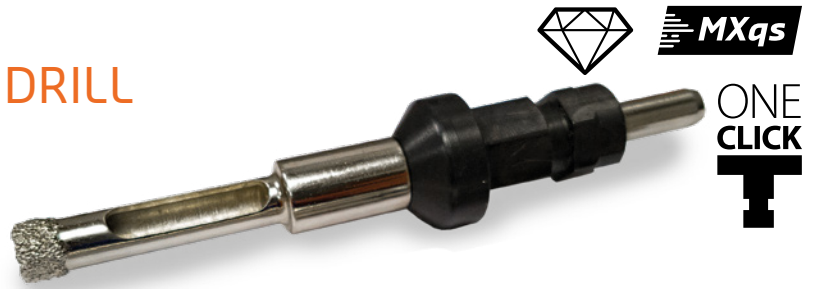

MXqs ProXcut PILOT DRILL



MXQDA004B
MXqs ProXcut diamond drill including adapter MXQDA003B



MXQDA003B
Separate adapter to use as the first drilling step with the ProXcut Pilot drill - 3 Pieces/package

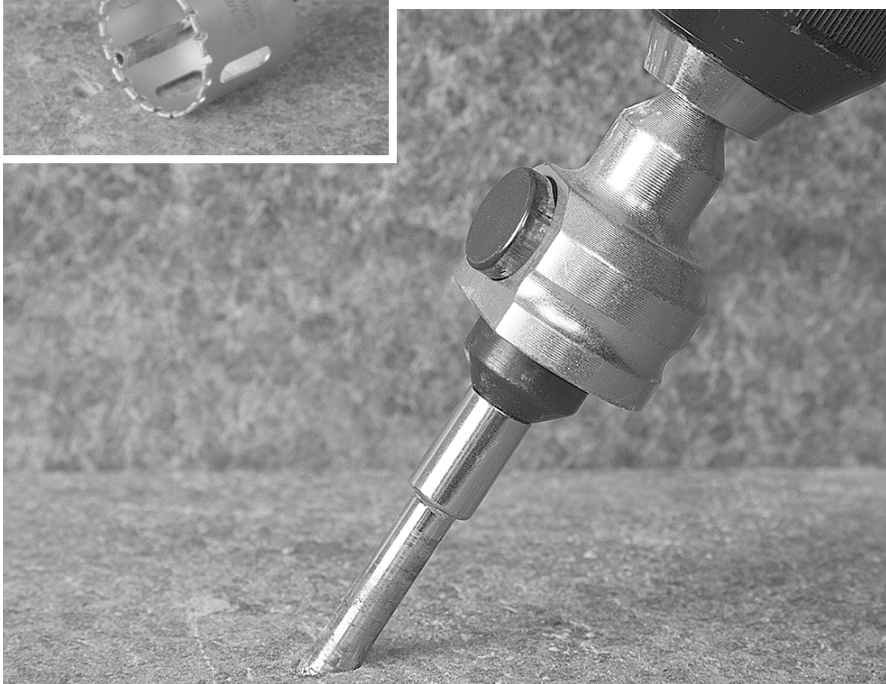
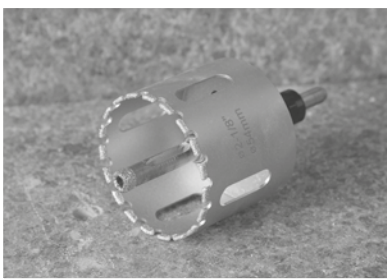

1 Drill your center hole with the MXqs arbor, in combination with the proXcut center drill, 'clicked' into the adapter. (set MXQDA004B)

2 Remove the pilot drill with adapter and secure the MXqs arbor on the diamond Hole Saw with "ONE CLICK". Push the ProXcut center drill into the arbor.

3 Position the ProXcut center drill in the hole you have already drilled. After this, you can drill accurately and securely.

To extend the lifetime of the ProXcut pilot drill, you can remove it after drilling a few mm with the large Hole Saw. Simply pull the ProXcut center drill out of the arbor.

DIAMOND DRYXCUT

These diamond grit edge Hole Saws have been specially developed for professionals who need to drill in extremely hard materials. With the extreme long life time these saws are for the most difficult jobs.

When used with the unique DryXcut pilot drill (page 31) there is a low risk of slipping!

FEATURES

- Up to 10 times longer lifetime
- Dry drilling, no water required
- Clean edges and fast, accurate cuts
- Premium grade diamond grit
- Ideal for tiles, granite and hard and natural stone (e.g. marble)
- Cutting depth is 35mm (1-3/8")
- Small diameters (Ø5-18mm) with **cooling wax** ●
- Side holes for release of slurry
- Suitable for use with high speed electric or battery powered drilling/grinding machines



*To order this type of diamond Hole Saw with M14x2 thread for grinders, change the "Q" in the Part No. for "0"

MXqs Diamond ARBORS

	MX2P1006B MXqs Arbor Drill Chuck Hex 11 - 7/16"PB	
	MX2P1007B MXqs Arbor Drill Chuck Hex 8,5 - 11/32"PB	
	MX2P1006SB MXqs Arbor SDS-PLUS Drill Chuck SDS-plus	

MXqs DryXcut ADAPTER

	MX2P0057B MXqs diamond ONE CLICK adapter only to use with DryXcut hole saws with M14x2 thread. 3 Piece
---	---



Part No.*	Ø MM	Ø INCH	Wax
MHD2Q005B	5	3/16	●
MHD2Q006B	6	1/4	●
MHD2Q008B	8	5/16	●
MHD2Q010B	10	3/8	●
MHD2Q012B	12	1/2	●
MHD2Q014B	14	9/16	●
MHD2Q016B	16	5/8	●
MHD2Q018B	18	23/32	●
MHD2Q020B	20	25/32	
MHD2Q022B	22	7/8	
MHD2Q025B	25	1	
MHD2Q027B	27	1 1/16	
MHD2Q030B	30	1 3/16	
MHD2Q032B	32	1 1/4	
MHD2Q035B	35	1 3/8	
MHD2Q038B	38	1 1/2	
MHD2Q040B	40	1 9/16	
MHD2Q041B	41	1 5/8	
MHD2Q045B	45	1 25/32	
MHD2Q050B	50	1 31/32	
MHD2Q051B	51	2	
MHD2Q054B	54	2 1/8	
MHD2Q055B	55	2 5/32	
MHD2Q057B	57	2 1/4	
MHD2Q060B	60	2 3/8	
MHD2Q064B	64	2 1/2	
MHD2Q065B	65	2 9/16	
MHD2Q068B	68	2 11/16	
MHD2Q073B	73	2 7/8	
MHD2Q075B	75	2 15/16	
MHD2Q076B	76	3	
MHD2Q082B	82	3 15/64	
MHD2Q083B	83	3 1/4	
MHD2Q092B	92	3 5/8	
MHD2Q102B	102	4	
MHD2Q112B	112	4 13/32	
MHD2Q132B	132	5 3/16	

MXqs DIAMOND WITH THE MOST STABLE DRYXCUT PILOT DRILL



MXQDA006B
MXqs DryXcut diamond drill including COOLING WAX including adapter MXQDA003B



MXQDA003B
Separate adapter to use as the first drilling step with the DryXcut Pilot drill - 3 Pieces/ package

Accurate positioning and stable drilling with the unique DryXcut center drill.

Besides the benefits of the Mandrex MXqs ONE CLICK arbor system, the DryXcut center drill has been developed to make your work easier and safer. The DryXcut center drill lowers the risk of slipping and raises the accuracy of positioning.

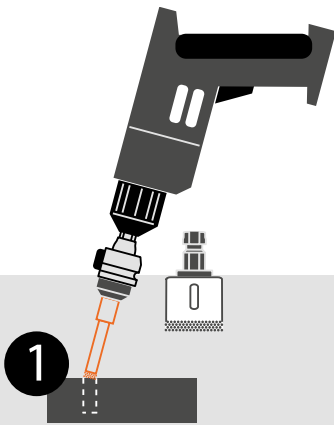

1 Drill your center hole with the MXqs arbor, in combination with the DryXcut center drill, 'clicked' into the adapter. (set MXQDA006B)

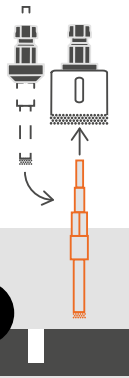

2 Remove the pilot drill with adapter and secure the MXqs arbor on the diamond Hole Saw with "ONE CLICK". Push the DryXcut center drill into the arbor.

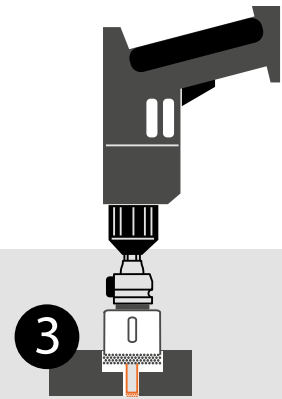

3 Position the DryXcut center drill in the hole you have already drilled. After this, you can drill accurately and securely.

DIAMOND DRYXCUT KITS

Mandrex DryXcut sets are created to function under heavy duty conditions. All Diamond DryXcut Hole Saws are produced for use with angle grinders with M14 shaft connection.



Part No.	ØMM	Ø INCH	Total Pieces	EXTRA Drill Guide
MHDS20001	5, 6, 8, 10, 12	3/16, 1/4, 5/16, 3/8, 1/2	6	MHD00001B
MHDS20002	5, 6, 8, 10, 12, 20, 32, 35	3/16, 1/4, 5/16, 3/8, 1/2, 25/32, 1-1/4, 1-3/8	8	
MHDS20003	5, 6, 8, 10, 12, 20, 32, 35, 68	3/16, 1/4, 5/16, 3/8, 1/2, 25/32, 1-1/4, 1-3/8, 2-11/16	9	
MHDS20004	25, 44, 57, 75	1, 1-3/8, 2-1/4, 2-15/16	4	
MHDS20005	2x 6, 2x 8, 10, 12, 14	2x 1/4, 2x 5/16, 3/8, 1/2, 9/16	7	
MHDS20006	20, 35, 40, 50, 55, 68	25/32, 1-3/8, 1-9/16, 1-31/32, 2-5/32, 2-11/16	6	

DIAMOND TILEXCUT

These diamond grit edge Hole Saws have been specially developed for professionals who need to drill in extremely hard materials. With the long life time these saws are for the most difficult jobs.

Drilling plugs and small holes is fast and easy. The lifetime is ensured, thanks to the cooling wax inside. Additional cooling wax can be ordered: Part.No MX200093B

FEATURES

- Dry drilling, no water required
- Clean edges and fast, accurate cuts
- Premium grade diamond grit
- Ideal for tiles, granite and hard and natural stone (e.g. marble)
- Maximum cutting depth is 28mm (1-1/8")
- With **cooling wax** inside
- 1/4" Powerbit connection
- Suitable for use with high speed electric or battery powered drilling
- Additional cooling wax can be ordered: Part.No MX200093B



COOLING WAX
+LIFETIME
+SPEED

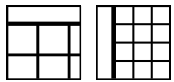

Part No.	Ø MM	Ø INCH
MHD21005B	5	3/16
MHD21006B	6	1/4
MHD21008B	8	5/16
MHD21010B	10	3/8
MHD21012B	12	1/2



5 Pieces Diamond Drill Bit set

MHDS21001

The perfect kit for drilling small (plug) holes in tiles, etc.
This set includes all suitable diameters: Ø5,6,8,10 and 12mm.

DIAMOND UNIxCUT

The Mandrex Arbored (one piece) vacuum brazed diamond grit Hole Saws are long-lasting and perfect for drilling in tiles and stone. Drilling is fast and easy thanks to the reduced pressure which is required for the perfect result.

FEATURES

- Oversized slot holes for easy plug removal
- Little pressure required during drilling
- Wet and dry drilling, minimal water required
- Suitable for use in low speed electric and battery powered drilling machines
- Clean edges and accurate cuts
- Ideal for tiles, granite and hard and natural stone
- No arbor required
- Maximum cutting depth is 28mm (1-1/8")

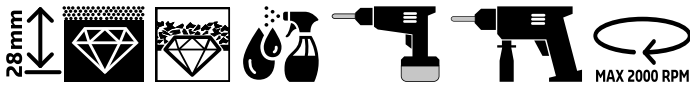
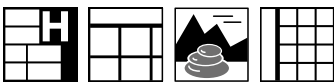

Part No.	Ø MM	Ø INCH
MHD30005B	5	3/16
MHD30006B	6	1/4
MHD30007B	7	9/32
MHD30008B	8	5/16
MHD30010B	10	3/8
MHD30012B	12	1/2
MHD30015B	15	9/16
MHD30020B	20	25/32
MHD30025B	25	1
MHD30030B	30	1 3/16
MHD30035B	35	1 3/8

5 Pieces Diamond Drill Bit set

MHDS30001

The perfect kit for drilling small (plug) holes in tiles, etc.

This set includes all suitable diameters: Ø5,6,8,10 and 12mm.



6 Pieces Diamond Drill Bit set

MHDS30002

For more accurate positioning and watercooling, this kit contains a professional centering and cooling device. The perfect kit for drilling small (plug) holes in tiles, etc. The set includes all suitable diameters: Ø5,6,8,10 and 12mm.



DIAMOND CORE DRILLS CONCRETE^XDRY

The Mandrex Concrete^Xdry core drills are robust and built to last under high-pressure conditions. The laser welded segments have been specially developed to ensure an extremely long lifetime.

Fast and clean cutting is ensured when used in combination with the Mandrex MXqs ONE CLICK Hole Saw system.

FEATURES

- High quality professional grade diamond
- Segment height 9mm
- Laser welded for strength and universal drilling
- Ideal for (soft) stone, brickwork and concrete
- Fast and accurate cuts
- Premium grade diamond segments
- Side holes for release of dust
- Cutting depth 60mm (2-3/8")
- Dry drilling, no water required

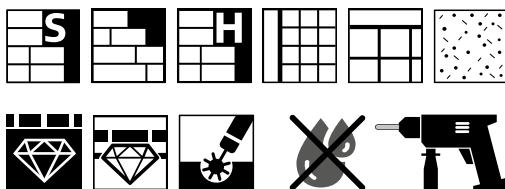

MXqs

**ONE
CLICK**



Part No.*	Ø MM	Ø INCH
MDDb1Q068B	68	2 11/16
MDDb1Q072B	72	2 13/16
MDDb1Q082B	82	3 15/64

MXqs Concrete^Xcut ARBORS, PILOT DRILL & ADAPTERS

**ONE
CLICK**



MX200027B
MXqs Arbor with TCT pilot drill
Drill Chuck Hex 11 - 7/16"PB



MX200028B
MXqs Arbor with TCT pilot drill
Drill Chuck Hex 8,5 - 11/32"PB



MX200029B
MXqs Arbor with TCT pilot drill
Drill Chuck SDS-plus



MX2P0067B
MXqs Pilot drill for Concrete^Xcut
with TCT tungsten carbide tip.
L=150mm



MX2P0058B
MXqs adapter with M16x2 thread for use with e.g.
Concrete^Xcut dry cut core drills. 3 Pieces/package

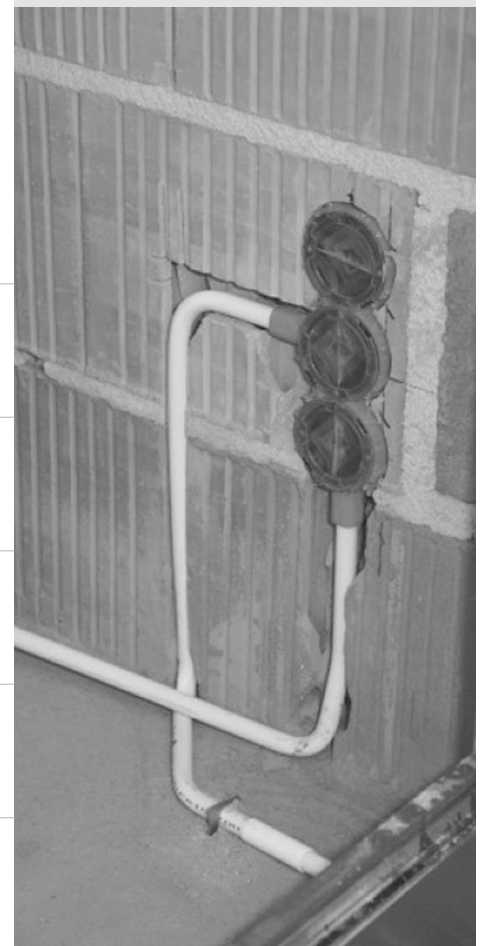

*To order Concrete^Xdry with M16x2 thread, replace the "Q" in the Part No. with "O"

DIAMOND CORE DRILLS CONCREXDUST DUSTFREE



When used together with the Mandrex ConcreteX DustXtractor, clean operation is ensured, with almost no additional cleaning required. It guarantees dust-free drilling of stone, brickwork and concrete.

The Mandrex diamond core drills are robust and built to last under high-pressure applications. The laser welded segments have been especially developed to ensure an extremely long lifetime.

FEATURES

- High quality 9mm height segments
- Laser welded for strength and universal drilling
- Ideal for (soft) stone, brickwork and concrete
- Fast and clean cutting due to the premium grade diamond segments
- A slot on the back to ensure clean operation (With the Mandrex ConcreteX DustXtractor Part No. MDDBA001)
- Clean edges and accurate cuts
- Cutting depth 60mm (2-3/8")
- Dry drilling, no water required

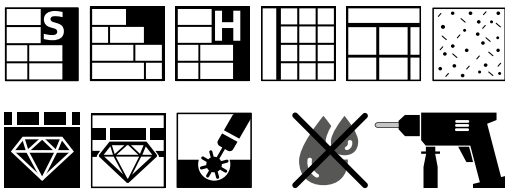

Part No.	Ø MM	Ø INCH
Mddb20068B	68	2 11/16
Mddb20072B	72	2 13/16
Mddb20082B	82	3 15/64

MDDBA001 ConcreteX DustXtractor

This dust extractor is designed for clean operation, with almost no additional cleaning required. It guarantees virtually dust-free drilling of stone and concrete.

Hose connection Ø30mm.
Machine connection 5/8"-16UNF

Must be used with
ConcreteXdust core drills.



MDDBA002
Center Point for secure and safe drilling in combination with the ConcreteX DustXtractor MDDBA001



MDDBA003
Adapter M16x2 Male - Hex including center drill



MDDBA004
Pilot Drill with TCT carbide tip for MDDBA003



MDDBA005
Adapter M16x2 Male - SDS plus including center drill



MDDBA006
Pilot Drill with TCT carbide tip for MDDBA005

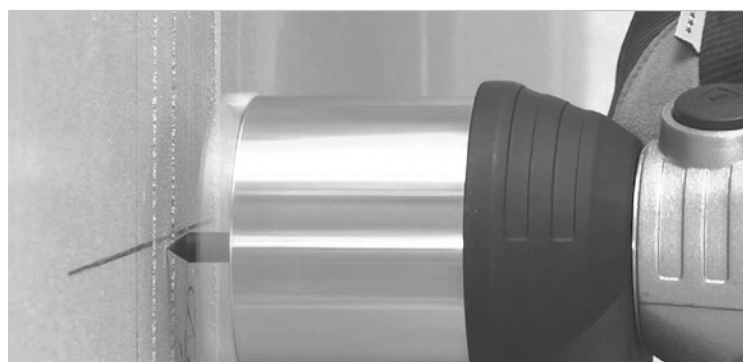

ACCESSORIES FOR HOLE SAWS



COOLING GEL

MX200092B

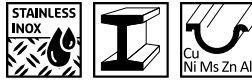

MandreX Cooling Gel is a modern, high-quality cutting lubricant with a high gap-filling propensity and excellent cooling properties. MandreX Cooling Gel can be used under normal circumstances for almost all drilling, tapping and cutting work. The product reduces friction, yields a nicely-finished surface and extends the service life of the cutting tools. The high-quality components that go to make up MandreX Cooling Gel also make it suitable for use on stainless steel and other hard materials. Directions for use: Shake well before applying the product directly to the cutting tool or object to be treated.



FEATURES

- Very high temperature range
- Strongly sticky
- Can be used on all types of metal
- High cooling capacity
- Ready to use

Applications

For optimum lubrication during drilling, cutting and tapping. Suitable for both hard and soft metals. Also suitable for stainless steel.

COOLING WAX

MX200093B

This COOLING WAX is specially developed for brazed diamond drills which require cooling. It can be used with the DryXcut, TileXcut and UniXcut diamond Hole Saws when drilling e.g. hard (natural) stone, porcelain and glazed tiles.

Dip your drill in the wax and cool down for a few seconds. It speeds up the drilling and increases the lifetime.



**+LIFETIME
+SPEED**



WATER SPRAY BOTTLE

MHD00002B

The MandreX pressurized water spray bottle is used to provide water cooling to diamond Hole Saws when drilling tiles, etc.

To be used in combination with centering and cooling aid MHD00001B/MHD00100B/MHD00101B
Max. filling capacity 0,9L.
Including 1.8m water hose.



CENTERING & COOLING AID

MHD00001B

Ideal for drilling clean and accurate holes in hard tiles, etc. Extra safety is guaranteed with an additional safety lock.

Can be used in combination with the pressurized water spray bottle MHD00002B.
Suitable for sizes: Ø5,6,8,10 and 12mm.



MANUAL CENTERING TOOL

MHD00100B

Easy manual centering and security device which allows you to drill secure and stable in all kinds of materials. Just push it against the surface and hold it while you drill. Suitable for drilling diameters till Ø35mm. Can be used both wet and dry.

When you need water: use the unique adjustable water supply. For the water supply you can use the water spray bottle MHD0002B. This smart tool can be used against any material and under many circumstances. It is stable because of the anti-slip rubber feet and the firm grip.

Mark the position where you want to drill by using the built in ruler. To make sure you are precise and straight you can use the horizontal or vertical levellers. No markings on the drill anymore? Compare your drill with the diameter of your wall-plug with the holes in the tool.



VACUUM CENTERING TOOL

MHD00101B

Easy vacuum mounted centering tool which allows you to drill secure and stable in all kinds of materials. Just push it against the surface and push down the handle to secure. This smart centering tool can be used against every smooth and non-porous material e.g. glazed wall tiles, kitchen sheet from marble or natural stone. When you need water: use the unique adjustable water supply.

For the water supply you can use the water spray bottle MHD0002B.

For Dust and Slurry extraction you can use the Mandrex Dust & Slurry Tool MHD00102B



DUST & SLURRY TOOL - SMALL

MHD00102B

Work CLEAN and SAFE with the DUST & SLURRY Tool. Protect yourself! Small particles you cannot see are the most dangerous! This smart tool can not only be used against every smooth and non-porous material (e.g. glazed wall tiles, kitchen sheet from marble or natural stone), but also against less abrasive materials (depending on the roughness and the capacity of the vacuum/dust-cleaner you use).

Can be used with and without the MHD00101B Vacuum Centering Device. Together with the Vacuum Centering Device you will get all the benefits: no dust, no slurry, perfect centering and prevention of slipping of the drill.



DUST & SLURRY TOOL - BIG

MHD00103B

Work CLEAN and SAFE with the big DUST & SLURRY Tool for holes **up to 102mm**. Protect yourself! Small particles you cannot see are the most dangerous!

This smart tool can not only be used against every smooth and non-porous material (e.g. glazed wall tiles, kitchen sheet from marble or natural stone), but also against less abrasive materials (depending on the roughness and the capacity of the vacuum/dust-cleaner you use).

Just push it against the surface and work dust free and clean!



ULTIMATE SPEEDXBIT

Extreme fast drilling of holes compared to conventional flat spade drill bits. Our unique self-feeding threaded **QuickTip™ Technology** enables the drill bit to effortlessly pull itself into the wood. Precision grounded cutting edges for faster drilling and longer life time and a black oxide finish for more durability.

Suitable for use on soft and hard wood, light building materials and plasterboard. This spade bit has a 1/4-inch hex shank and can be used in electric battery powered & cordless power tools, including impact drivers.

FEATURES

- Widest range of wood & wooden materials
- Extremely fast because of the self-feeding QuickTip™ technology
- Cutting depth 152 or 406mm
- Hex 1/4" powerbit shank
- Highest grade hardened steel cutting edges
- Suitable for use in electric & battery powered tools



QuickTIP™ TECHNOLOGY



Part No.	Ø MM	L	Hex	Part No.	Ø MM	L	Hex
MWS15006B	6	152	1/4"	MWS40006B	6	406	1/4"
MWS15008B	8	152	1/4"	MWS40008B	8	406	1/4"
MWS15010B	10	152	1/4"	MWS40010B	10	406	1/4"
MWS15012B	12	152	1/4"	MWS40012B	12	406	1/4"
MWS15013B	13	152	1/4"	MWS40013B	13	406	1/4"
MWS15014B	14	152	1/4"	MWS40014B	14	406	1/4"
MWS15015B	15	152	1/4"	MWS40015B	15	406	1/4"
MWS15016B	16	152	1/4"	MWS40016B	16	406	1/4"
MWS15018B	18	152	1/4"	MWS40018B	18	406	1/4"
MWS15020B	20	152	1/4"	MWS40020B	20	406	1/4"
MWS15022B	22	152	1/4"	MWS40022B	22	406	1/4"
MWS15024B	24	152	1/4"	MWS40024B	24	406	1/4"
MWS15025B	25	152	1/4"	MWS40025B	25	406	1/4"
MWS15028B	28	152	1/4"	MWS40028B	28	406	1/4"
MWS15030B	30	152	1/4"	MWS40030B	30	406	1/4"
MWS15032B	32	152	1/4"	MWS40032B	32	406	1/4"
MWS15035B	35	152	1/4"	MWS40035B	35	406	1/4"
MWS15038B	38	152	1/4"	MWS40038B	38	406	1/4"
MWS15040B	40	152	1/4"	MWS40040B	40	406	1/4"



Ultimate SpeedXbit Kits

Kits with the most used dimensions of flat spade bits including the QuickTip™ Technology, suitable for all woodworking jobs.

Part No.		Ø MM
MWS0001	8 Pieces Kit	12, 16, 18, 20, 22, 25, 28, 32
MWS0002	6 Pieces Kit	10, 12, 16, 18, 20, 25

ULTIMATE TWISTERXBIT

Auger Wood Bits for fast, powerful and accurate drilling in wood. Our unique self-feeding threaded **QuickTip™ Technology** enables the drill bit to effortlessly pull itself into the wood very deep.

Fast Chip removal and precise drilling due to our low friction flute geometry. Suitable for use on soft and hard wood, light building materials, plasterboard and framing.

Less friction and heat because of special diameter grinded flute below the drill point *

FEATURES

- For wood & wooden materials
- Extreme fast because of the self-feeding QuickTip™ technology
- Cutting depths 110, 230 and 460mm for extreme deep holes
- Precision grinded Auger bit
- Highest grade hardened steel
- Clean drilling
- Hex 1/4" or 3/8" shank



QuickTIP™
TECHNOLOGY

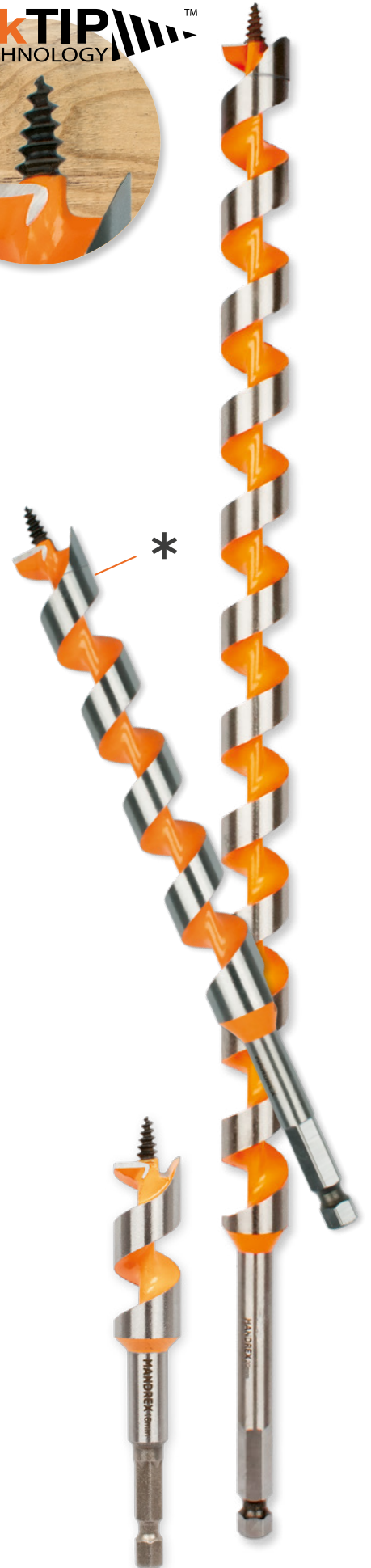

Part No.	Ø MM	L	Hex
MWA11006B	6	110	1/4"
MWA11008B	8	110	1/4"
MWA11010B	10	110	1/4"
MWA11012B	12	110	1/4"
MWA11013B	13	110	1/4"
MWA11014B	14	110	1/4"
MWA11016B	16	110	1/4"

Part No.	Ø MM	L	Hex
MWA46006B	6	460	1/4"
MWA46008B	8	460	1/4"
MWA46010B	10	460	1/4"
MWA46012B	12	460	1/4"
MWA46013B	13	460	1/4"
MWA46014B	14	460	1/4"
MWA46016B	16	460	1/4"
MWA46018B	18	460	1/4"
MWA46020B	20	460	3/8"
MWA46022B	22	460	3/8"
MWA46024B	24	460	3/8"
MWA46028B	28	460	3/8"
MWA46030B	30	460	3/8"
MWA46032B	32	460	3/8"
MWA46038B	38	460	3/8"

Part No.	Ø MM	L	Hex
MWA23006B	6	230	1/4"
MWA23008B	8	230	1/4"
MWA23010B	10	230	1/4"
MWA23012B	12	230	1/4"
MWA23013B	13	230	1/4"
MWA23014B	14	230	1/4"
MWA23016B	16	230	1/4"
MWA23018B	18	230	1/4"
MWA23020B	20	230	3/8"
MWA23022B	22	230	3/8"
MWA23024B	24	230	3/8"
MWA23026B	26	230	3/8"
MWA23028B	28	230	3/8"
MWA23030B	30	230	3/8"
MWA23032B	32	230	3/8"
MWA23038B	38	230	3/8"



ULTIMATE 4X POWERXBIT

Spiral flute Wood Bits with 4 cutting edges for faster and very accurate drilling in wood. Our unique self-feeding threaded QuickTip™ Technology enables the drill bit to effortlessly pull itself into soft and hard wood.

Fast Chip removal in hard and soft wood, 5 times quicker compared to standard auger bits and more precise drilling due to our low friction grinded flute geometry and 4 cutting edges. This fast and accurate drill bit has a 1/4-inch hex shank and can be used in cordless and corded impact and drill drivers and drill benches

FEATURES

- For hard and soft wood
- more than 5 times faster
- Extreme fast because of the self-feeding QuickTip™ technology
- Cutting depth 160mm and Hex 1/4" shank
- Highest grade hardened steel, extremely wear-resistant cutting edges
- Precision grinded 4 cutting edges
- Clean and straight drilling



QuickTIP™ TECHNOLOGY



Part No.	Ø MM	L	Hex
MWF16012B	12	160	1/4"
MWF16014B	14	160	1/4"
MWF16016B	16	160	1/4"
MWF16018B	18	160	1/4"
MWF16020B	20	160	1/4"
MWF16022B	22	160	1/4"
MWF16024B	24	160	1/4"
MWF16025B	25	160	1/4"
MWF16026B	26	160	1/4"
MWF16028B	28	160	1/4"
MWF16030B	30	160	1/4"
MWF16032B	32	160	1/4"



Mandrex Wood Drill Extension HEX 1/4"

Accurate extensions to use with all wooddrills with 1/4" shank. Made from high alloy hardened steel for safe, accurate deep holes or spaces difficult to reach. It is easy to change the bit with the quick release connection.

Part No.		L	Shank
MWE150B	Wood Drill Extension	152mm	1/4" to 1/4" Quick Release
MWE300B	Wood Drill Extension	300mm	1/4" to 1/4" Quick Release



RECIPROCATING SAW BLADE SELECTOR

Select a material and you will see which reciprocating saw blade is most suitable.

Material

	MRT10B	MRH10B MRH11B MRH12B	MRF10B	MRF11B MRF12B	MRM10B MRM11B MRM12B	MRM17B	MRS10B MRS11B MRS12B MRS13B	MRW10B MRW11B	MRV10B	MRV11B	MRV12B
Wood / Plywood				●	●	●			●	●	●
Soft wood				●				●	●	●	●
MDF				●	●	●					
Wood with nails				●	●	●			●	●	●
Multiplex				●					●		●
Pallets											●
Window frames					●	●					
Garden wood								●			
Steel/Iron					●		●		●		●
Sheet steel			●		●		●		●	●	
Stainless Steel / Inox			●				●		●		
Steel profiles / tubes			●				●		●	●	●
Non ferrous									●		●
Cast iron	●										
Common plastics / PVC				●							
Reinforced plastics				●	●	●			●	●	●
Fibre cement board	●										
Soft stone Gypsum / Stucco	●	●									
Brickwork		●									
Wall tiles	●										
Hard (floor-) tiles	●										



HIGH QUALITY
MADE IN GERMANY



3X FastCUT LONG LIFE

3X FASTCUT

The **TRIPPLE-sided 3X FASTCUT** is a professional grade saw blade that fits all reciprocating saws. With 8% cobalt for exceptional strength, versatility and durability.

Plunge cut without rattling your teeth. With its rounded tip and its double edged blade you can cut in both directions without flipping your saw over!



FEATURES

- **TRIPPLE-sided, cuts 3 ways**
- 8% cobalt for long-lasting metal cutting
- Exceptional strength, versatility and durability
- Rounded tip plunge cuts with ease
- Cuts wood with nails, pipe, sheet metal, plastic, fiberglass and other materials
- Optimized blade grind, set and kerf
- Cost-effective — two blades for the price of one!

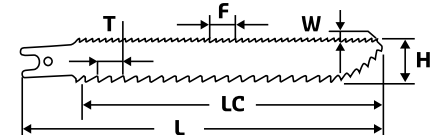

Part.No	Pcs pack	L	LC	H	W	T	F
MRF10B	2	150	130	19	0,9	1,8	1,4
MRF11B	2	150	130	19	0,9	4,2	2,5
MRF12B	2	200	180	19	1,27	4,2	2,5

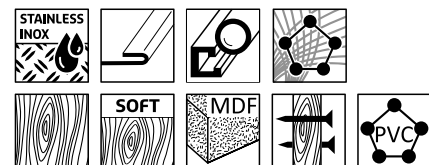

STEELCUT

High quality bi-metal saw blades for **cutting sheet metal, pipes and profiles**. For each thickness we have designed the perfect saw blade. There is no kind of steel too strong for our Steelcut bi-metal blades. These saw blades are known for their exceptional strength, versatility and durability



FEATURES

- Exceptional strength, versatility and durability
- Special design to cut all kinds of steel
- Bi-metal milled blade
- Universal shank

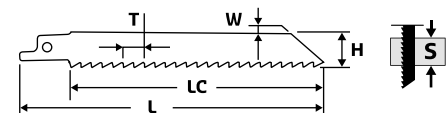

Part.No	Pcs pack	L	LC	H	W	T	S
MRS10B	2	150	130	19	0,9	1,4	1,5-4
MRS11B	2	150	130	19	0,9	1,8	3-8
MRS13B	2	230	210	19	0,9	1,4	1,5-4
MRS12B	2	230	210	19	0,9	1,8	2-8

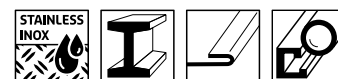

MULTICUT

Top quality multi-purpose saw blades for everyday applications. Ensures outstanding cutting, smooth and fast under heavy conditions. These Multicut blades are known for the wide range of materials they can be used for including wood with nails.



Part.No	Pcs pack	L	LC	H	W	T	S
MRM11B	2	150	130	19	1,27	4,2	6-100
MRM12B	2	230	210	19	1,27	4,2	6-180
MRM10B	2	300	280	19	1,27	4,2	6-250

FEATURES

- Exceptional strength, versatility and durability
- Fast cutting
- Multi-purpose blade
- Bi-metal milled blade
- Universal shank

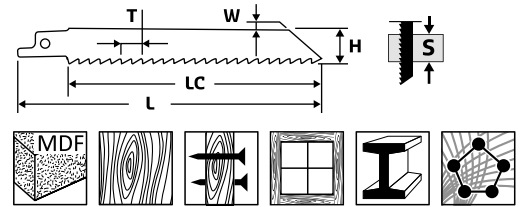

MULTICUT VARIA

Fine tooth multi-purpose saw blades with variable pitch. Perfect for cutting sheet metal and other thin materials. Ensures outstanding cutting, smooth and precise. These Multicut Varia blades are known for the wide range of materials they can be used for including wood with nails.



Part.No	Pcs pack	L	LC	H	W	T	S
MRV10B	2	150	130	19	0,9	1,8-2,5	3-100
MRV12B	2	230	210	19	0,9	1,8-2,5	3-190
MRV11B	2	300	280	19	0,9	1,8-2,5	3-250

FEATURES

- Exceptional strength, versatility and durability
- Fast cutting
- Fine tooth blade
- Variable pitch
- Universal shank

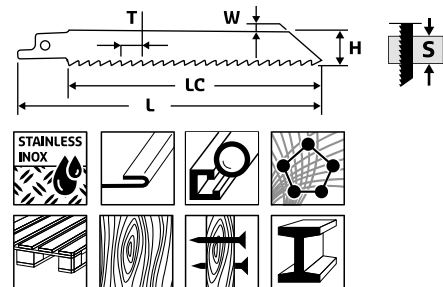

MULTICUT DEMOLITION & RENOVATION

Extra thick, top quality, multi-purpose saw blades with special design for the **demolition and renovation** branches. Ensures outstanding cutting under heavy conditions. These Multicut saw blades are known for the wide range of materials they can be used for including wood with nails.



Part.No	Pcs pack	L	LC	H	W	T	S
MRM17B	2	230	210	19	1,27	4,2	6-180

FEATURES

- Extra Thick
- Exceptional strength, versatility and durability
- Fast cutting
- Multi-purpose blade
- Bi-metal milled blade
- Universal shank

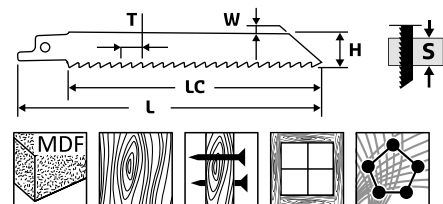

HARDCUT

Top quality Tungsten Carbide Teeth combined with the power of this reciprocating saw give you the strength to cut through brick & mortar, stone, cinderblock, reinforced plastics, gypsum and many more materials. The special design is ideal for curve cuts and the high grade carbide teeth ensures a long lifetime.



Part.No	Pcs pack	L	LC	H	W	T	S
MRH10B	1	210	190	46	2,97	18	30-80
MRH11B	1	300	280	46	2,97	18	30-200
MRH12B	1	460	440	46	2,97	18	30-350

FEATURES

- Fits any reciprocating saw
- Professional Grade
- Fast cutting application for otherwise difficult jobs
- Exceptional strength, versatility and durability
- Ideal for curve cuts

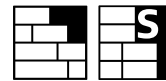
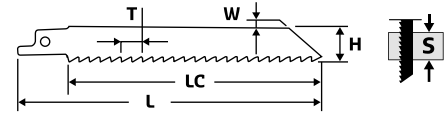

TOUGH CUT

This superior reciprocating saw blade with heavy duty industrial **diamond grit** which ensures smooth straight cutting through the hardest materials. Can be used for cutting cast iron, fibreglass, cement board, carbon fibre, bricks, building blocks, concrete etc.



Part.No	Pcs pack	L	LC	H	W	S
MRT10B	1	200	180	19	0,9	2-100



FEATURES

- Heavy duty industrial grit
- Exceptional strength, versatility and durability
- Blade length 200mm
- Universal shank

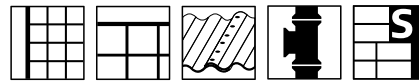
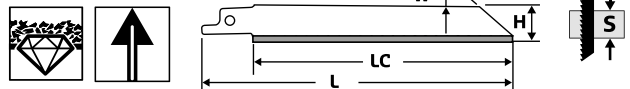

WOODCUT

Top quality **Chrome Vanadium** saw blades for cutting softwood, construction wood, firewood, timber etc. There is no kind of wood too strong for our Woodcut blades. Made in Germany these blades are known for their exceptional strength



Part.No	Pcs pack	L	LC	H	W	T	S
MRW10B	2	230	210	19	1,2	8,5	20-150
MRW11B	2	230	210	19	1,2	5-6,5	15-190

FEATURES

- Exceptional strength, versatility and durability
- Top quality to cut all kinds of wood
- German made Chrome Vanadium blades
- Universal shank

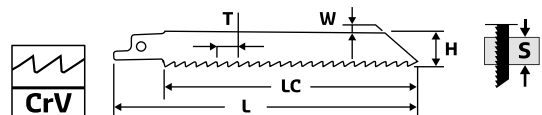

JIG SAW BLADE SELECTOR

Select a material or performance and you will see which jig saw blade is most suitable.

Performance

	MSC10B	MSD10B	MSD11B	MSV10B	MSV11B
Straight cut	●			●	●
Curve cut		●	●		
Precise angle					
Very clean cut	●	●			●
Rough cut			●	●	
High-speed cut	●		●		
Stays cooler	●				
XL Extra-long blade				●	●

Material

	MSC10B	MSD10B	MSD11B	MSV10B	MSV11B
Wood / Plywood	●	●	●	●	
Soft wood	●	●	●	●	
MDF	●	●	●		
Wood with nails				●	
Multiplex	●		●		●
Laminated board	●	●	●		
Laminate	●				
Steel/Iron				●	
Sheet steel					●
Stainless Steel / Inox				●	
Steel profiles / tubes					●
Non ferrous				●	●
Cast iron					
Common plastics / PVC					●
Reinforced plastics					●

COOLCUT

Perfect straight cuts with our unique top quality Coolcut jig saw blade. Made in Germany using patented laser technology. This saw blade features parallel cut and an open framework design that helps dissipate frictional heat. The forward pointing teeth are designed for extra splinter free cut. These unique shaped blades offer highly precise cuts while maintaining superior blade durability



Part.No	Pcs pack	L	LC	H	W	T	S
MSC10B	2	100	75	8	1,45	2	3-60

FEATURES

- Unique saw blade design
- Open framework design to dissipate frictional heat
- Parallel shape for super straight cuts
- Superior durability
- Pointing teeth for extra splinter free cuts

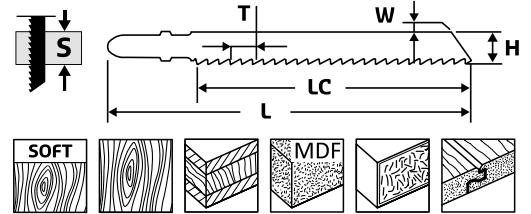

DUOCUT

Our durable, hardened-steel double sided Duocut jig saw blades delivers extraordinary tight cuts with unmatched precision, speed and clean edges. This innovative blade will cut in all directions, with superior performance. The Duocut cuts (splinter-free) all kinds of wood and wood based products.



Part.No	Pcs pack	L	LC	H	W	T	S
MSD10B	2	100	75	8	1,45	2,5	4-30

FEATURES

- For extra clean curved cutting
- Chrome Vanadium hardened steel
- Milled backside teeth for extra clean curved cuts
- Fast and smooth splinter-free cuts
- Double-edged blade cuts both ways

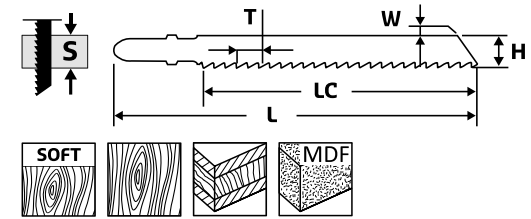

DUOCUT VARIA

Our **variable pitch double sided** Duocut Varia jig saw blade delivers extraordinary tight cuts with unmatched precision, speed and clean edges. This innovative blade will cut in all directions, with superior performance. The Duocut cuts (splinter-free) all kinds of wood and wood based products



Part.No	Pcs pack	L	LC	H	W	T	S
MSD11B	2	115	95	8	1,45	2,2-3,2	3-90

FEATURES

- Cut any curve of angle. No matter how tight
- Chrome Vanadium hardened steel
- Variable pitch laser-tech teeth
- Fast and smooth splinter-free cuts
- Double-edged blade cuts both ways

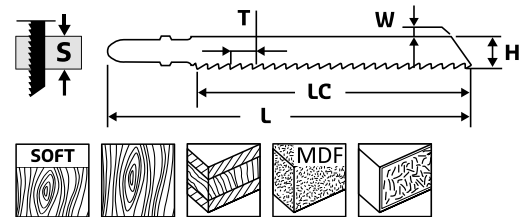

SHARPCUT VARIA

Professional Jig saw blades for universal applications in wood and metal materials. **Conically grounded blade with sharpened teeth.** For fast and clean cuts. Made in Germany, using patented laser technology, makes these universal blades exceptional strong and versatile.

FEATURES

- Bi-metal saw blade
- For universal applications
- Exceptional strength, versatility and durability
- For wood with nails
- Universal shank



Part.No	Pcs pack	L	LC	H	W	T	S
MSV10B	2	132	110	8	1,27	1,8-2,5	3-100

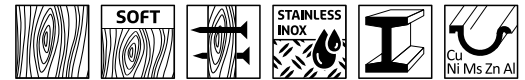
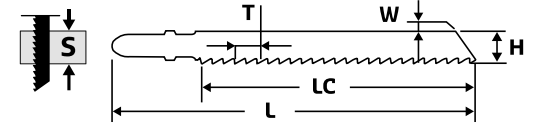

Part.No	Pcs pack	L	LC	H	W	T	S
MSV11B	2	132	110	8	1,0	1,0-1,6	1,2-6



MSS10B













MULTI-PURPOSE-PACK (5PCS)



This 5 pieces Mandrex Multi-purpose Jig saw assortment includes 1 piece of MSC10B, MSD10B, MSD11B, MSV10B and MSV11B each. This Mandrex Multi-purpose pack can handle all materials and meets all your requirements: assembled with the best jig saw blades



DIAMOND SAW BLADE SELECTOR

Select a material and you will see which diamond saw blade is most suitable.

Quality Rating	Type		Quality	Speed	Lifetime
	XtremePro	The best and most extreme saw blade in our range. All benefits which are needed to cut professional with extreme lifetime, speed and result.			
	Profi	Professionals need to have the best performance, speed and cost/cut. That's what Profi blades are used for: Fast cutting and proper lifetime.			
	Standard	The most suitable quality for users who want a good result.			

	 XtremePro				 Profi		 Standard
	Bricks	Tiles	Concrete	Universal	Tiles	Universal	Universal
Bricks	<input type="checkbox"/>			<input type="checkbox"/>		<input type="checkbox"/>	<input type="checkbox"/>
Pavement bricks/ blocks	<input type="checkbox"/>		<input type="checkbox"/>				<input type="checkbox"/>
Clay Bricks / Poroton	<input type="checkbox"/>						
Cement	<input type="checkbox"/>						
Mortar	<input type="checkbox"/>						
Roof tiles	<input type="checkbox"/>			<input type="checkbox"/>		<input type="checkbox"/>	<input type="checkbox"/>
Stone		<input type="checkbox"/>	<input type="checkbox"/>	<input type="checkbox"/>	<input type="checkbox"/>	<input type="checkbox"/>	<input type="checkbox"/>
Natural stone		<input type="checkbox"/>			<input type="checkbox"/>	<input type="checkbox"/>	
Floor tiles		<input type="checkbox"/>			<input type="checkbox"/>	<input type="checkbox"/>	
Wall tiles		<input type="checkbox"/>			<input type="checkbox"/>	<input type="checkbox"/>	
Tiles		<input type="checkbox"/>			<input type="checkbox"/>	<input type="checkbox"/>	
Marble		<input type="checkbox"/>			<input type="checkbox"/>	<input type="checkbox"/>	
Porcelain		<input type="checkbox"/>			<input type="checkbox"/>		
Concrete			<input type="checkbox"/>	<input type="checkbox"/>		<input type="checkbox"/>	<input type="checkbox"/>
Green concrete	<input type="checkbox"/>		<input type="checkbox"/>				
Reinforced concrete			<input type="checkbox"/>				
Concrete pipe			<input type="checkbox"/>				
Limestone / Ytong	<input type="checkbox"/>		<input type="checkbox"/>				
Sandstone	<input type="checkbox"/>		<input type="checkbox"/>				
Asphalt	<input type="checkbox"/>		<input type="checkbox"/>	<input type="checkbox"/>		<input type="checkbox"/>	<input type="checkbox"/>
Cast iron				<input type="checkbox"/>		<input type="checkbox"/>	<input type="checkbox"/>
Steel				<input type="checkbox"/>		<input type="checkbox"/>	<input type="checkbox"/>

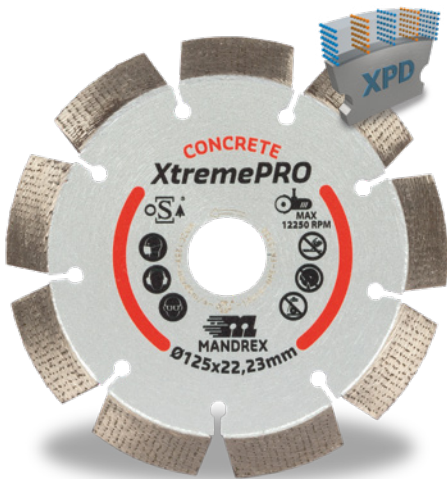

CONCRETE - XtremePRO

Top performance laser welded blades with unique XPD technology. Guarantees a long lifetime and fast cutting results.

FEATURES

- Segments with **XPD Technology**
- Laser welded
- For all construction materials
- Dry use
- Segment height 12mm



Part.No	D	A	H	W	T
MDZC115X	115	22,23	12	32	2,3
MDZC125X	125	22,23	12	32	2,3
MDZC230X	230	22,23	12	40	2,6

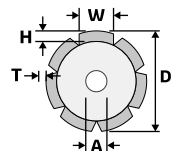

It is almost impossible to have a perfect solution for diamond saw blades. A blade which can be used in every situation under any condition and which cuts fast, long and with the highest efficiency.

OUR MANDREX DIAMOND SAW BLADES HAVE THIS SOLUTION:

In the Mandrex diamond saw blades we have incorporated our high-tech XPD Technology. With this technology we are able to create the perfect grid layout in three dimensional patterns. Each diamond can work optimally and can be kept cool under any conditions.

The performance stays consistent at all times and you will experience that these blades cut faster, strong, more efficient and much longer!

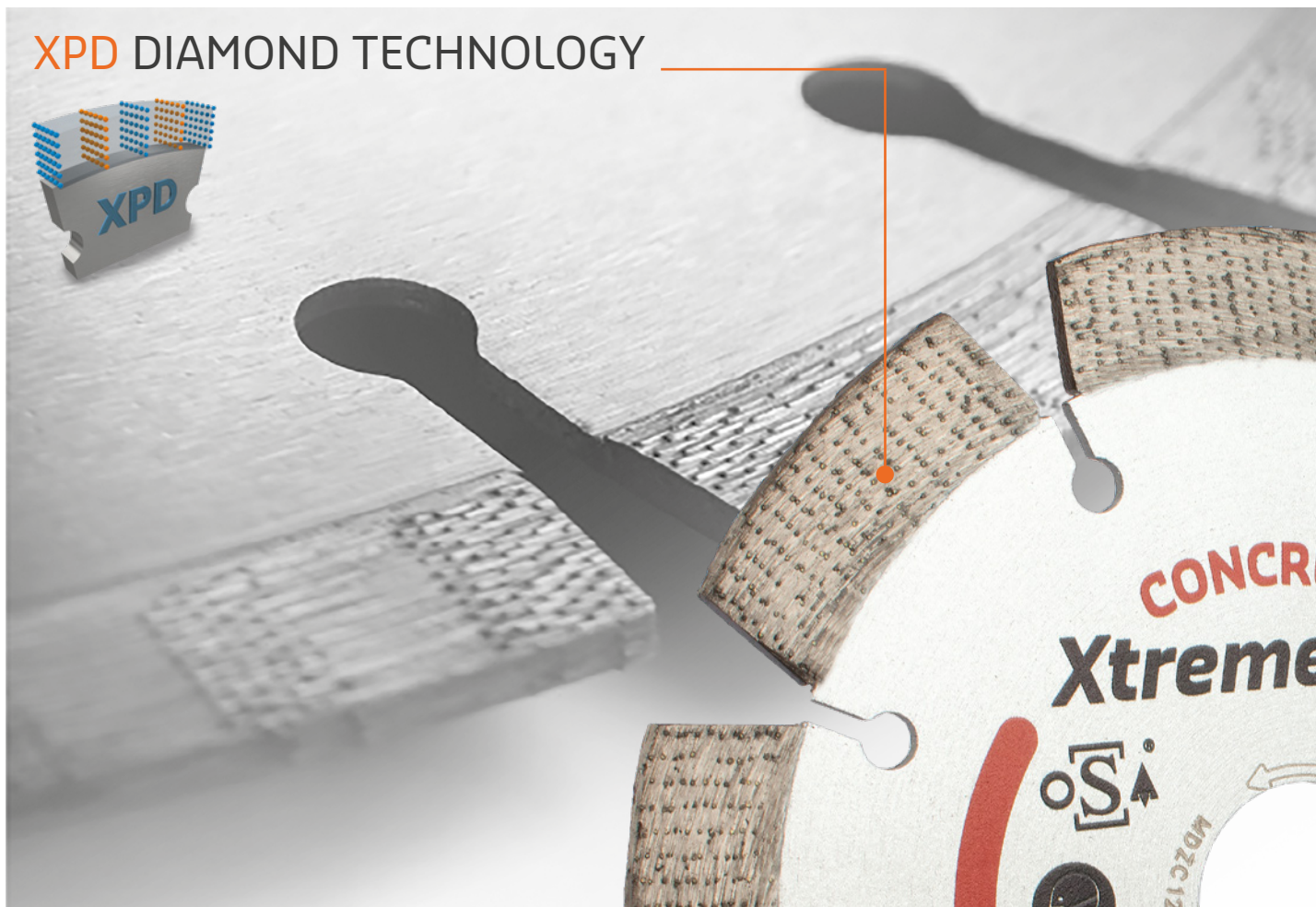

XPD DIAMOND TECHNOLOGY



UNIVERSAL - XtremePRO

Top performance laser welded blades for multi-purpose use. With special design release slots and a segment height of 12mm for unique cutting results and a long lifetime.

FEATURES

- Laser welded
- Multi-purpose use
- Special designed release slots
- Dry use
- Segment height 12mm



Part.No	D	A	H	W	T
MDZU115X	115	22,23	12	34	2,3
MDZU125X	125	22,23	12	32	2,3
MDZU230X	230	22,23	12	40	2,4

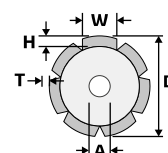

UNIVERSAL - PROFI

Professional laser welded blades. Wide release slots for fast cutting results

FEATURES

- Laser welded blades
- For multi-purpose use
- Wide release slots
- Dry use
- Segment height 10mm



Part.No	D	A	H	W	T
MDZU115P	115	22,23	10	34	2,3
MDZU125P	125	22,23	10	32	2,3
MDZU150P	150	22,23	10	40	2,6
MDZU230P	230	22,23	10	38	2,6

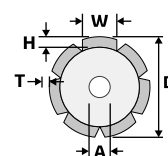

UNIVERSAL - STANDARD

Universal Sintered blades for multi-purpose use with good cutting results.

FEATURES

- Sintered Blade
- Multi-purpose use
- Dry use
- Segment height 10mm



Part.No	D	A	H	W	T
MDZU115S	115	22,23	10	30	1,8
MDZU125S	125	22,23	10	30	1,8
MDZU150S	150	22,23	10	34	2,0
MDZU230S	230	22,23	10	38	2,4

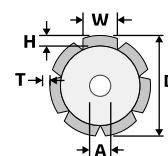

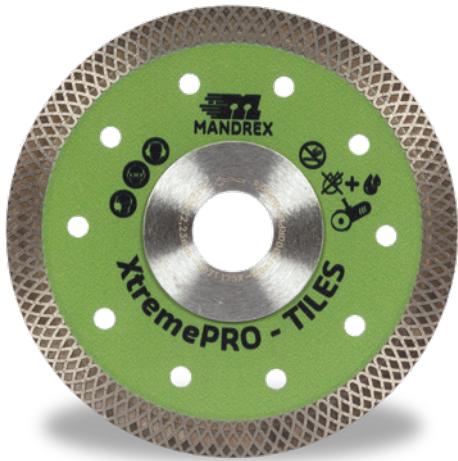

TILES - XtremePRO

Super Thin blades with reinforced core which are specially designed to cut the hardest ceramic tiles. Guarantees a long lifetime and fast cutting results.

FEATURES

- Super thin blade
- Special design for hard ceramic tiles
- Dry and Wet use
- Segment height 10mm



Part.No	D	A	H	W	T
MDZT115X	115	22,23	10	FULL	1,4
MDZT125X	125	22,23	10	FULL	1,4

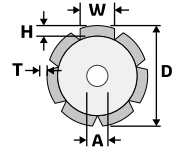

TILES - PROFI

Professional quality continuous rim blades to cut tiles and porcelain. For fast cutting results.

FEATURES

- Continuous rim blade
- For tile and porcelain
- Dry and wet use
- Segment height 7mm



Part.No	D	A	H	W	T
MDZT115P	115	22,23	7	FULL	1,6
MDZT125P	125	22,23	7	FULL	1,6

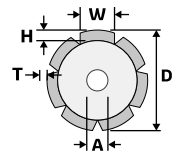

BRICKS - XtremePRO

Top performance segmented blades with unique protection segments for a long lifetime and fast cutting

FEATURES

- Segmented blades with protection segments
- For abrasive materials
- Dry use
- Segment height 10mm



Part.No	D	A	H	W	T
MDZB125X	125	22,23	10	34	2,0
MDZB150X	150	22,23	10	35	2,2
MDZB230X	230	22,23	10	33	2,6

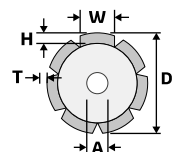

DIAMOND CUT-OFF DISC METALXCUT

The Diamond Edge Cut-off discs from Mandrex feature a diamond abrasive edge, combined with a shatter-resistant steel core. This combined, ensures safe operation, reduced dust and debris and an extreme long lifetime.

The Mandrex MetalXcut diamond cut-off discs are designed to retain its cutting power up to 50 times longer than typical bonded abrasive products. The thin walls of the discs ensure quick clean cuts through almost any material including (stainless) steel, cast iron, rebar, masonry and many more.

Because of the high performance diamond technology the diamond does not wear off with each cut which means they keep their diameter and width throughout the lifetime of the disc. The Mandrex MetalXcut diamond cut-off discs have a **lifetime of 1,000 or more cuts** (up to 30 times longer life than thin bonded cut-off wheels)*

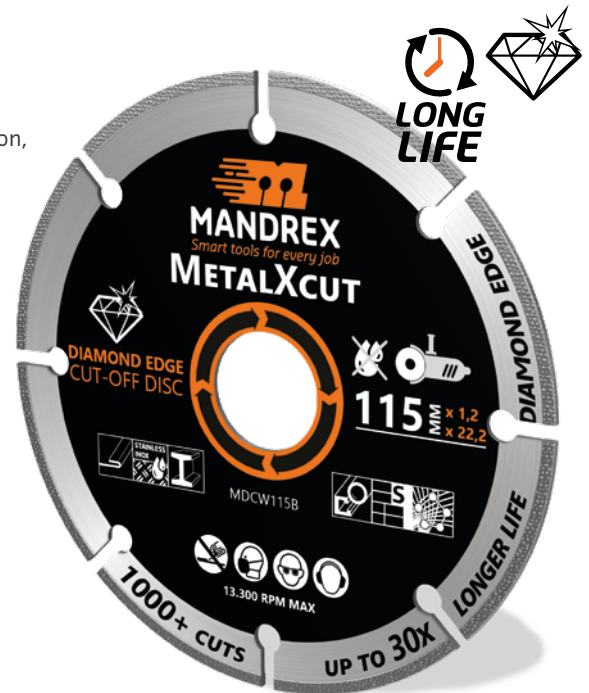

FEATURES

- High performance diamond technology
- Up to **30 times longer lifetime** than typical bonded abrasive products
- Extreme durability in metal cutting applications
- Safe shatter-resistant steel core
- Reduced dust and debris during use
- Cutting depth remains unchanged during the lifetime of the blade
- The **lowest cost per cut**

Part.No	D	A x t	T	Max RPM
MDCW115B	115	22,2 x 1,2	1,6	13.300
MDCW125B	125	22,2 x 1,2	1,6	12.200
MDCW150B	150	22,2 x 1,6	1,8	10.100
MDCW180B	180	22,2 x 1,6	1,8	8.400
MDCW230B	230	22,2 x 1,6	2,0	6.800
MDCW300B	300	25,4 x 2,0	2,4	5.000
MDCW350B	350	25,4 x 2,2	2,6	4.300

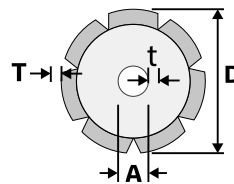

Steel
Carbon steel
Stainless steel
Thin sheet metal
Metal pipe / profile
Copper / Brass
Aluminium
Masonry
Plasterboard
Fibre cement
Soft stone
Gypsum
Soft tiles
Soft brick
Reinforced plastic



*Average performance for 115mm wheel in 1" carbon steel square tube vs thin bonded abrasive cut-off wheels.

EZYGRIND

EZYGRIND - DIAMOND COATED PIPE CUTTER

The Mandrex EzyGrind is the safest & fastest way to cut plastic pipes at or below floor level by inserting the tool inside the pipe and cutting from the inside. It is especially suited to concrete slab construction, and difficult to access areas.

Using the Mandrex EzyGrind will enable you to produce a clean professional finish with one cutting action. The Mandrex EzyGrind is designed to cut PVC and HDPE pipes (sizes from Ø40 – 150mm). Suitable for pipes including encased pipes, pipe penetrations, conduits, storm water, sewer, WC's, shower drains, floor wastes, down pipes and inspection openings.

The Mandrex EzyGrind is your safest choice as it works with a power drill, while cutting from inside the pipe protects the user from blade contact. The alternate method of using an angle grinder will cause potential safety problems. Many governments recommend using an alternative to an angle grinder wherever possible.



The 7mm Hex Powerbit Shank fits all drill chucks for use with all kinds of (cordless-) power drills. Maximum rotation speed is 2500 rpm.

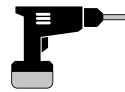

Replaceable Diamond Blades with Diamond coating for smooth cutting in abrasive materials.



Includes two cutting guides for controlled cutting depth, white for standard PVC and black for HDPE pipes.



EZYGRIND Pipe Cutter



MEZG001B

EzyGrind Pipe Cutter - Small
7mm Hex Powerbit shank

Pipe diameter - Ømm
DWV HDPE (HD-) PVC

40-65 50-75 50-80

MEZG002B

EzyGrind Pipe Cutter - Big
7mm Hex Powerbit shank

90-150 90-150 100-150

EZYGRIND Replacement discs



MEZG010B

For the EzyGrind MEZG001B (Small) - 2 Pieces / pack

MEZG110B

For the EzyGrind MEZG002B (Big) - 2 Pieces / pack

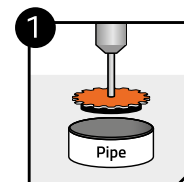

1 Insert the EzyGrind inside PVC pipe. Begin cutting by pushing firmly against the pipe wall until it cuts through

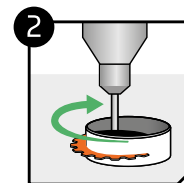

2 Operate in a clockwise direction. Maintain outward pressure.

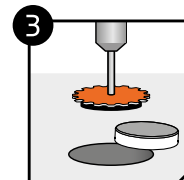

3 Keep drill parallel to the pipe for a perfect cut.



Mandrex
Tuindersweg 28 b
2676 BH Maasdijk
The Netherlands
Tel: +31 174 52 80 77
sales@mandrex-system.com

MandreX-Catalogue-EN-2024-V4b

Specifications subject to change

The patented MandreX MXqs system is licensed to Mandrex Hole Saw System in the Netherlands for distribution worldwide.

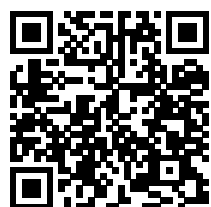

WWW.MANDREX-SYSTEM.COM