

15-4 Seperator with separating diameter 30 mm - 200 mm, 65 mm usable cutting depth (mounting thread G5/8)



DESCRIPTION

The pulling devices of series 15 are used in conjunction with the pulling devices of series 18 for the removal of ball bearings, roller bearings, inner rings, and other flat components in crafts, industry, and workshops, when there is not enough space for puller jaws. The separating-pulling process is capable of initially separating those parts gently before they can be pulled off from the outside.

APPLICATION AREA

Together with the extractors of series 18 for extracting ball bearings, roller bearings, inner rings and other parts in flat contact with the surface

BENEFIT

- The sharp edges allow for extraction where other extraction methods are not applicable.
- By screwing together the separation and pulling device, the highest stability during pulling is ensured.
- If the separating jaws are screwed into the pulling device the other way around, the support area is enlarged and removed more gently.

OPERATION

- Press the sharp edges of the separating device behind the part
- Clamp the separating jaws using the pressure spindle by evenly tightening the adjusting nuts on the side bolts of the separating device and ensure that the separating knives sit firmly underneath the part to be removed
- Screw the pull bolt of the puller device into the threaded holes of the separating device until it stops
- Hold the separating device and securely and carefully remove the relevant part by tightening the clamping nut

MASTER DATA

| | |
|-------------------------------|---------------|
| GTIN [EAN] | 4021176007378 |
| Country of origin | DE |
| Case material | Tool steel |
| Series | 15 |
| Net weight [kg] | 11,8 kg |
| Package contents | 1 piece |
| Packaging Act | PAP 21 |
| Global sales capability given | Yes |

SPARE PARTS

- 015401_Side bolt with nut

APPLICATION IMAGE



Seperator with separating diameter 30 mm - 200 mm, 65 mm usable cutting depth (mounting thread G5/8)

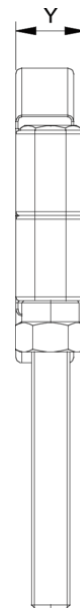
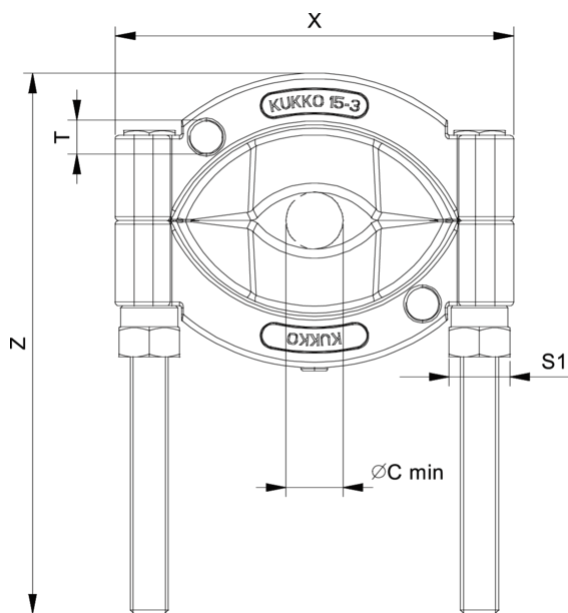

| Abbreviation | Attribut | Wert |
|--------------|---|---------|
| X | Total width [mm] | 280 mm |
| Y | Total depth [mm] | 42 mm |
| Z | Total height [mm] | 390 mm |
| S1 | Width across flats [mm] | 41 mm |
| Cmin | Cut-off diameter (min.) [mm] | 30 mm |
| Cmax | Separating diameter (max.) [mm] | 200 mm |
| K | Cutting edge thickness at the tip [mm] | 2 mm |
| O | Usable snow depth [mm] | 65 mm |
| H | Total cutting edge height [mm] | 103 mm |
| L | Rear cutting edge thickness [mm] | 15,6 mm |
| T1 | Mounting thread for tension bolt [nominal dimension] G5/8 | |

| Abbreviation | Attribut | Wert |
|--------------|---|---------|
| X | Total width [mm] | 280 mm |
| Y | Total depth [mm] | 42 mm |
| Z | Total height [mm] | 390 mm |
| S1 | Width across flats [mm] | 41 mm |
| Cmin | Cut-off diameter (min.) [mm] | 30 mm |
| Cmax | Separating diameter (max.) [mm] | 200 mm |
| K | Cutting edge thickness at the tip [mm] | 2 mm |
| O | Usable snow depth [mm] | 65 mm |
| H | Total cutting edge height [mm] | 103 mm |
| L | Rear cutting edge thickness [mm] | 15,6 mm |
| T1 | Mounting thread for tension bolt [nominal dimension] G5/8 | |

A-A

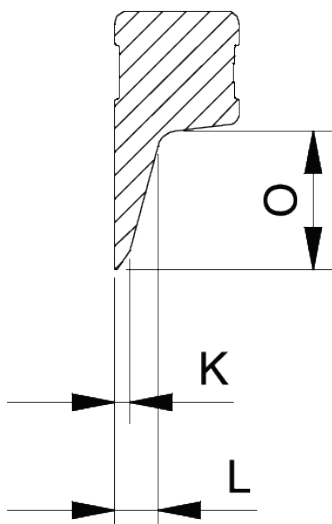

| Abbreviation | Attribut | Wert |
|--------------|--|---------|
| X | Total width [mm] | 280 mm |
| Y | Total depth [mm] | 42 mm |
| Z | Total height [mm] | 390 mm |
| S1 | Width across flats [mm] | 41 mm |
| Cmin | Cut-off diameter (min.) [mm] | 30 mm |
| Cmax | Separating diameter (max.) [mm] | 200 mm |
| K | Cutting edge thickness at the tip [mm] | 2 mm |
| O | Usable snow depth [mm] | 65 mm |
| H | Total cutting edge height [mm] | 103 mm |
| L | Rear cutting edge thickness [mm] | 15,6 mm |
| T1 | Mounting thread for tension bolt [nominal dimension] | G5/8 |