

15-3 Seperator with a separating diameter of 30 mm - 150 mm, 50 mm usable cutting depth (mounting thread M18x1,5)



APPLICATION IMAGE



DESCRIPTION

The pulling devices of series 15 are used in conjunction with the pulling devices of series 18 for the removal of ball bearings, roller bearings, inner rings, and other flat components in crafts, industry, and workshops, when there is not enough space for puller jaws. The separating-pulling process is capable of initially separating those parts gently before they can be pulled off from the outside.

APPLICATION AREA

Together with the extractors of series 18 for extracting ball bearings, roller bearings, inner rings and other parts in flat contact with the surface

BENEFIT

- The sharp edges allow for extraction where other extraction methods are not applicable.
- By screwing together the separation and pulling device, the highest stability during pulling is ensured.
- If the separating jaws are screwed into the pulling device the other way around, the support area is enlarged and removed more gently.

OPERATION

- Press the sharp edges of the separating device behind the part
- Clamp the separating jaws using the pressure spindle by evenly tightening the adjusting nuts on the side bolts of the separating device and ensure that the separating knives sit firmly underneath the part to be removed
- Screw the pull bolt of the puller device into the threaded holes of the separating device until it stops
- Hold the separating device and securely and carefully remove the relevant part by tightening the clamping nut

MASTER DATA

GTIN [EAN]	4021176007293
Country of origin	DE
Case material	Tool steel
Series	15
Net weight [kg]	5,3 kg
Package contents	1 piece
Packaging Act	PAP 21
Global sales capability given	Yes

SPARE PARTS

- 015270_side bolt with nut

Seperator with a separating diameter of 30 mm - 150 mm, 50 mm usable cutting depth (mounting thread M18x1,5)

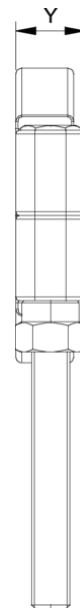
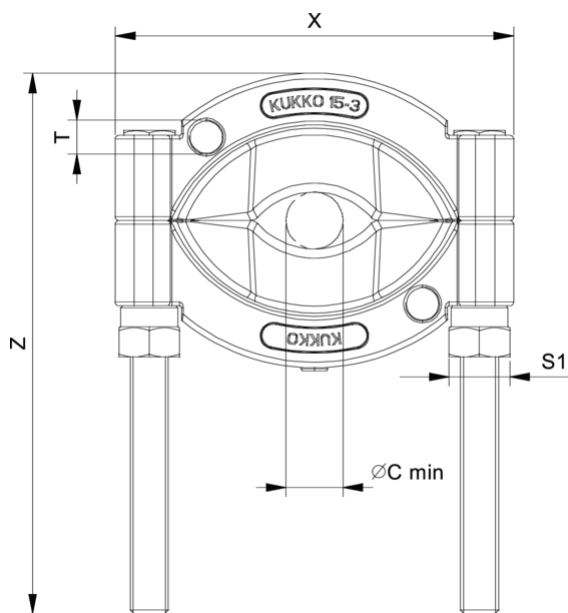

Abbreviation	Attribut	Wert
X	Total width [mm]	210 mm
Y	Total depth [mm]	36 mm
Z	Total height [mm]	255 mm
S1	Width across flats [mm]	32 mm
Cmin	Cut-off diameter (min.) [mm]	30 mm
Cmax	Separating diameter (max.) [mm]	150 mm
K	Cutting edge thickness at the tip [mm]	0,5 mm
O	Usable snow depth [mm]	50 mm
H	Total cutting edge height [mm]	78 mm
L	Rear cutting edge thickness [mm]	11,2 mm
T1	Mounting thread for tension bolt [nominal dimension] M18x1,5	

Abbreviation	Attribut	Wert
X	Total width [mm]	210 mm
Y	Total depth [mm]	36 mm
Z	Total height [mm]	255 mm
S1	Width across flats [mm]	32 mm
Cmin	Cut-off diameter (min.) [mm]	30 mm
Cmax	Separating diameter (max.) [mm]	150 mm
K	Cutting edge thickness at the tip [mm]	0,5 mm
O	Usable snow depth [mm]	50 mm
H	Total cutting edge height [mm]	78 mm
L	Rear cutting edge thickness [mm]	11,2 mm
T1	Mounting thread for tension bolt [nominal dimension] M18x1,5	

A-A

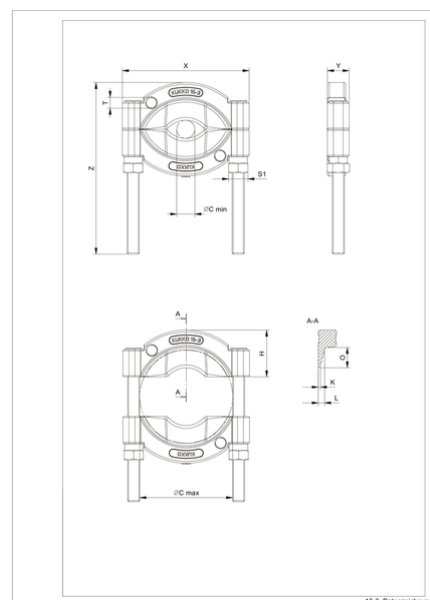
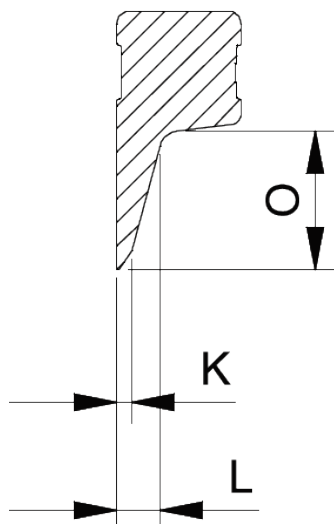

Abbreviation	Attribut	Wert
X	Total width [mm]	210 mm
Y	Total depth [mm]	36 mm
Z	Total height [mm]	255 mm
S1	Width across flats [mm]	32 mm
Cmin	Cut-off diameter (min.) [mm]	30 mm
Cmax	Separating diameter (max.) [mm]	150 mm
K	Cutting edge thickness at the tip [mm]	0,5 mm
O	Usable snow depth [mm]	50 mm
H	Total cutting edge height [mm]	78 mm
L	Rear cutting edge thickness [mm]	11,2 mm
T1	Mounting thread for tension bolt [nominal dimension]	M18x1,5

Abbreviation	Attribut	Wert
X	Total width [mm]	210 mm
Y	Total depth [mm]	36 mm
Z	Total height [mm]	255 mm
S1	Width across flats [mm]	32 mm
Cmin	Cut-off diameter (min.) [mm]	30 mm
Cmax	Separating diameter (max.) [mm]	150 mm
K	Cutting edge thickness at the tip [mm]	0,5 mm
O	Usable snow depth [mm]	50 mm
H	Total cutting edge height [mm]	78 mm
L	Rear cutting edge thickness [mm]	11,2 mm
T1	Mounting thread for tension bolt [nominal dimension]	M18x1,5